



TAMA  
**TAMA**<sup>®</sup>  
SUPERSTAR

**TAMA**<sup>®</sup>

**DRUMS AND HARDWARE**

Price List 2024-07

Złoty (PL)



# REGULAR SNARE DRUMS

## MASTERCRAFT "THE BELL BRASS"

In 1980, the TAMA Mastercraft Bell Brass snare drum was born. At the time, the Bell Brass was designed to match the explosive sounds of a new decade in music and delivered the purest snare sound ever achieved. Widely used in heavy rock music of the 80s and 90s, TAMA's Bell Brass snare drum came to simply be known as "THE TERMINATOR". As aggressive of a sound it produced, its versatility was unmatched as it found its way into the hands of the world's top Jazz & Fusion drummers of the era.

Now, nearly half a century later, the TAMA Mastercraft "The Bell Brass" 50th Anniversary Reissue pays tribute to this legendary sound. Featuring a special alloy of copper and tin and molded into a 3mm thick shell, this super heavy bell brass shell produces extreme volume and outstanding tonal range.

Faithfully reproduced to original specifications as much as modern technology allows, the Mastercraft "The Bell Brass" 50th Anniversary Reissue brings the iconic & timeless sound to drummers once again.



### BB-156

Shell: 3mm Cast Bell Brass

Size: 14"x6.5"

Lug: Original Superstar Lug (6371N)

Hoop: Die-Cast Hoop (10 hole)

Strainer/Butt: Roller Action (6302N/6303N/6338N)

Snare Wire: 20 strands Carbon Steel Long Snare Wires (6035N)

Inside Muffler: One Touch Tone Control (6552N)

Head: REMO® Ambassador Coated TAMA 50th Anniversary version

**17.356,00**



355mm diameter, 3mm Cast Bell Brass Shell



Die-Cast Hoop (10 hole)



20 strands Carbon Steel Long Snare Wires (6035N)



Original Superstar Badge



One Touch Tone Control



REMO® Ambassador Coated  
TAMA 50th Anniversary version







# LIMITED SNARE DRUMS

## 50TH LIMITED MASTERCRAFT ROSEWOOD

In the 1980s, TAMA's Mastercraft Rosewood Snare Drum was the first and only drum of its kind. As a hard and dense material, Rosewood is commonly used as guitar fretboards, and at the time was only found on drums as a single outer-ply veneer. Full Rosewood drums are extremely difficult to produce, but their pure sound and dark tone makes them extremely popular among drummers looking for a new sound. Not long after the original release of the Mastercraft Rosewood Snare Drum, the TAMA brand became synonymous with Rosewood. This 50th Anniversary Limited Edition model faithfully reproduces the sound of the past. Familiar to those who were there at the beginning, and an exciting new discovery to those who weren't.



### RW-256

Shell: 7.5mm 15ply Indian Rosewood  
Size: 14"x6.5"  
Lug: Original Superstar Lug (6371N)  
Hoop: Die-Cast Hoop (10 hole)  
Strainer/Butt: Roller Action (6302N/6303N/6338N)  
Snare Wire: 20 strands Carbon Steel Long Snare Wires (6035N)  
Inside Muffler: One Touch Tone Control (6552N)  
Head: REMO® Ambassador Coated TAMA 50th Anniversary version

**4.336,00**



### RW-255

Shell: 7.5mm 15ply Indian Rosewood  
Size: 14"x5"  
Lug: Original Superstar Lug (6371N)  
Hoop: Die-Cast Hoop (10 hole)  
Strainer/Butt: Roller Action (6302N/6303N/6338N)  
Snare Wire: 20 strands Carbon Steel Long Snare Wires (6035N)  
Inside Muffler: One Touch Tone Control (6552N)  
Head: REMO® Ambassador Coated TAMA 50th Anniversary version

**4.249,00**

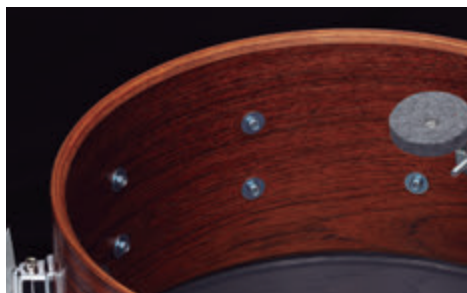

7.5mm, 15ply All Indian Rosewood Shell



Die-Cast Hoop (10 hole)



20 strands Carbon Steel Long Snare Wires (6035N)



One Touch Tone Control



Inside Muffler



REMO® Ambassador Coated  
TAMA 50th Anniversary version



# LIMITED SNARE DRUMS

## 50<sup>TH</sup> LIMITED MASTERCRAFT ARTWOOD

Released in 1980, fans of the Mastercraft Artwood snare drum have eagerly awaited its reissue. Known for its obviously stunning looks, this snare drum is adorned with a beautifully stained multi-section center wood inlay. The 9mm/6ply all-Birch shell delivers significant low-mid tone and clear projection. For a detailed & sensitive snare response, the drum features TAMA's unique Roller Action Strainer, an innovative full-contact snare wire design that utilizes a single on/off lever & dual guide rollers for easy & versatile adjustment. This faithful reproduction of TAMA's original Mastercraft Artwood snare drum is an amazingly beautiful celebration of TAMA's 50th Anniversary.



### AW-456

- Shell: 9mm 6ply Birch with center wood inlay
- Size: 14"x6.5"
- Lug: Original Superstar Lug (6371N)
- Hoop: Die-Cast Hoop (10 hole)
- Strainer/Butt: Roller Action (6302N/6303N/6338N)
- Snare Wire: 20 strands Carbon Steel Long Snare Wires (6035N)
- Inside Muffler: One Touch Tone Control (6552N)
- Head: REMO® Ambassador Coated TAMA 50th Anniversary version

**3.902,00**



### AW-455

- Shell: 9mm 6ply Birch with center wood inlay
- Size: 14"x5"
- Lug: Original Superstar Lug (6371N)
- Hoop: Die-Cast Hoop (10 hole)
- Strainer/Butt: Roller Action (6302N/6303N/6338N)
- Snare Wire: 20 strands Carbon Steel Long Snare Wires (6035N)
- Inside Muffler: One Touch Tone Control (6552N)
- Head: REMO® Ambassador Coated TAMA 50th Anniversary version

**3.815,00**



9mm, 6ply All Birch shell



Die-Cast Hoop (10 hole)



20 strands Carbon Steel Long Snare Wires (6035N)



One Touch Tone Control



Inside Muffler



REMO® Ambassador Coated  
TAMA 50th Anniversary version





# LIMITED SNARE DRUMS

## 50<sup>TH</sup> LIMITED MASTERCRAFT STEEL

Popular amongst vintage drum lovers, the Mastercraft Steel Snare Drum features a classic chrome finish and center groove design for a distinct and understated look. This 50th Anniversary Reissue model features a 1.2mm steel shell and die-cast hoops producing a clean, bright attack with clear and crisp resonance. Complete with full-surface snare wires for enhanced articulation, the Mastercraft Steel 50th Anniversary Reissue Snare Drum perfectly delivers the sound of the 80s.



**8056**

Shell: 1.2mm Steel  
Size: 14"x6.5"  
Lug: Original Superstar Lug (6371N)  
Hoop: Die-Cast Hoop (10 hole)  
Strainer/Butt: Roller Action (6302N/6303N/6338N)  
Snare Wire: 20 strands Carbon Steel Long Snare Wires (6035N)  
Inside Muffler: One Touch Tone Control (6552N)  
Head: REMO® Ambassador Coated TAMA 50th Anniversary version

**3.468,00**

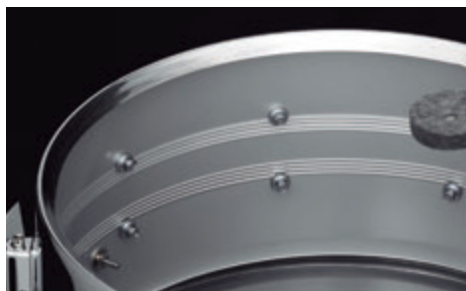

1.2mm Steel Shell



Die-Cast Hoop (10 hole)



20 strands Carbon Steel Long Snare Wires (6035N)





# LIMITED 50<sup>TH</sup> LIMITED SUPERSTAR REISSUE

Released just 2 years after the birth of the TAMA brand, Superstar drums were dynamic and powerful, laying the groundwork for the future of TAMA's sound. Now, almost 50 years later, the original Superstar drums have been revived as a Limited Edition model to celebrate the 50th Anniversary of TAMA Drums. Superstar was the world's first drum kit to utilize an all-Birch shell, producing the perfect sound for the emerging genres of the time - a sound that captivated the top drummers in the world. The groundbreaking 6-ply/9mm shell design was crucial to Superstar's monumental success. Thicker than modern drums, these shells achieved powerful attack and deep low end. Honoring TAMA's 50th Anniversary, the original shells, period correct shell hardware, and matching interior finish deliver a faithful reproduction of the original Superstar. Available in 4 popular original colors: Aqua Marine, Cherry Wine, Super Mahogany, and Super Maple. After 50 years, we celebrate the origin of TAMA's sound with the Superstar Reissue.



**COLOR** Aqua Marine (AQM)

### SU42RS basic kit

Including  
 22"x14" Bass Drum  
 10"x8" & 12"x8" Tom Toms  
 16"x16" Floor Tom  
 MTH800 Double Tom Holder

**8.676,00**



Shell: 6ply/9.0mm All Birch



Original Superstar Badge



REMO® Head

## AVAILABLE FINISHES



Aqua Marine (AQM)



Super Maple (SPM)



Super Mahogany (SMH)



Cherry Wine (CHW)





# LIMITED 50<sup>TH</sup> LIMITED STARCLASSIC MIRAGE

Since the 1970s, acrylic drums have been sought after for their unique sound and sleek look. Over the last two decades, TAMA has released limited edition acrylic drum kits of our own, starting with the Starclassic Mirage in 2007. To commemorate TAMA's beginnings, the Starclassic Mirage will return as a limited edition 50th Anniversary model. Characterized by strong attack and thunderous tone, Starclassic Mirage's seamless acrylic shells delivers unmatched sound and stunning looks. In addition to its controlled, punchy, and rich sound, acrylic remains unaffected by changing climates, making it perfect for use in any environment. The darker Black Nickel shell hardware perfectly complements the clear shells, ensuring that audiences and drummers alike will be instantly captivated by their stage presence.



**COLOR** Crystal Ice (CI)

### MBA52RZBNS basic kit

- Including
- 22"x16" Bass Drum
- 10"x7" & 12"x8" Tom Toms
- 14"x12" Floor Tom
- 16"x14" Floor Tom
- MC69 Single Tom Attachment x 2

**10.846,00**

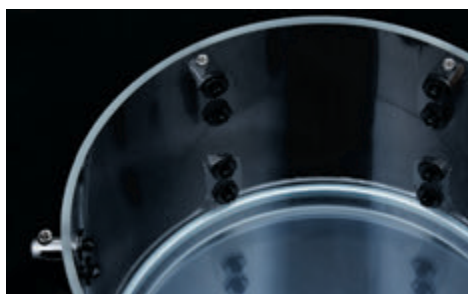

**Shell:**  
BD: 6.5mm Seamless Acrylic  
TT, FT: 5.5mm Seamless Acrylic



**Black Nickel Shell Hardware**



## ADD-ON SNARE DRUM



### MBAS65BN

- Shell: 5.5mm Seamless Acrylic
- Size: 14"x6.5"
- Lug: MSL-SCTBN
- Hoop: Die Cast Hoops (10 hole)
- Strainer/Butt: MLS30ABN/MLS30BBN
- Snare Wire: 20 strands Super Sensitive Hi-Carbon Snare Wires (MS20RL14C)
- Color: Crystal Ice (CI)

**1.949,00**



# LIMITED 50<sup>TH</sup> LIMITED IRON COBRA MARBLE Coral Swirl

## HP900PMCS / HP900PWMCS / HP900RMCS / HP900RWMCS

Since its release in 1993, the Iron Cobra has been the world's most highly rated pedal. At the core of the Iron Cobra series sits originality, and an unwavering commitment to constant innovation and evolution. With numerous limited edition models over the last two decades, this 50th Anniversary Limited Edition model serves as a special celebration of the Iron Cobra's long and storied history. Featuring two colorful designs, Coral Swirl and Psychedelic Rainbow, the Iron Cobra Marble Edition pedals are visually stunning, yet again setting the Iron Cobra apart from all others in its class.



**HP900PMCS**  
Power Glide Single Pedal

**1.732,00**



**HP900PWMCS**  
Power Glide Twin Pedal

**3.685,00**



**HP900RMCS**  
Rolling Glide Single Pedal

**1.732,00**



**HP900RWMCS**  
Rolling Glide Twin Pedal

**3.685,00**

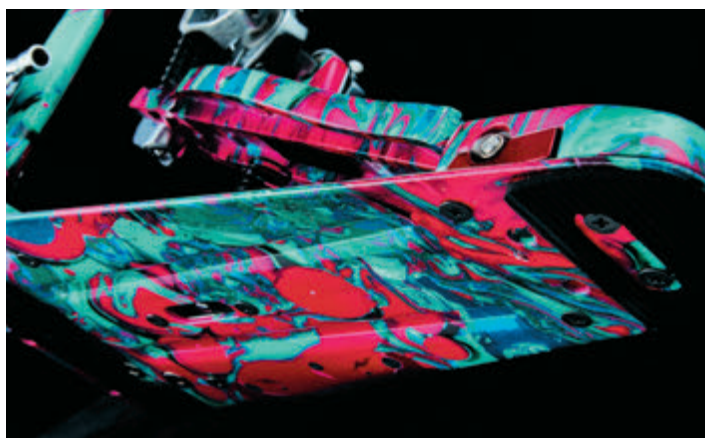





# LIMITED 50<sup>TH</sup> LIMITED IRON COBRA MARBLE Psychedelic Rainbow

## HP900PWMPR / HP900RMPR / HP900RWMPR

Since its release in 1993, the Iron Cobra has been the world's most highly rated pedal. At the core of the Iron Cobra series sits originality, and an unwavering commitment to constant innovation and evolution. With numerous limited edition models over the last two decades, this 50th Anniversary Limited Edition model serves as a special celebration of the Iron Cobra's long and storied history. Featuring two colorful designs, Coral Swirl and Psychedelic Rainbow, the Iron Cobra Marble Edition pedals are visually stunning, yet again setting the Iron Cobra apart from all others in its class.



**HP900PWMPR**  
Power Glide Twin Pedal  
**3.685,00**



**HP900RMPR**  
Rolling Glide Single Pedal  
**1.732,00**



**HP900RWMPR**  
Rolling Glide Twin Pedal  
**3.685,00**





# LIMITED ACCESSORIES

## 50TH LIMITED QUICK-SET CYMBAL MATE - QC8

TAMA's best-selling Quick-Set Cymbal Mate is available in three vibrant 50th Anniversary Limited Edition colors - Gray, Orange, and Purple.



**QC8B4GY**

**77,00**



**QC8B4OR**

**78,00**



**QC8B4PU**

**78,00**

\*Only 4pcs/set is available

## 50TH LIMITED DRUMSTICKS

Available as a 50th Anniversary Limited Edition model, TAMA releases a drumstick made from 100% Japanese Oak. With over 60 years of history, TAMA drumsticks date back to the brand's earliest years, and have remained popular amongst drummers around the world for their high-end and consistent quality.



**5A-50TH**

Material: Japanese Oak  
Diameter: 14mm  
Length: 406mm  
Tip Style: 5A

**52,00**



**5B-50TH**

Material: Japanese Oak  
Diameter: 15mm  
Length: 406mm  
Tip Style: 5B

**52,00**



**7A-50TH**

Material: Japanese Oak  
Diameter: 13mm  
Length: 390mm  
Tip Style: 7A

**52,00**







Starclassic **Mirage**



# TAMA STAR BUBINGA

## Lacquer Finishes

STAR is the flagship line for TAMA drums. It takes the knowledge and research we cultivated for the Starclassic series to the next level, by reexamining every detail to enhance shell resonance. STAR Bubinga features a thin 5mm shell. Every shell comes equipped with 9mm thick Sound Focus Rings (SFR) for structural support. This shell configuration provides clear projection and resonance to highlight the distinct sound of Bubinga.



**COLOR** Pewter Blue Australian Acacia **PBA**

including:  
22"x16" bass drum  
8"x6" tom tom  
10"x7" tom tom  
12"x8" tom tom  
14"x12" floor tom  
16"x14" floor tom  
14"x6.5" snare drum



**COLOR** Solid Candy Red **SDR**

including:  
20"x16" bass drum  
8"x7" tom tom  
10"x7" tom tom  
12"x7" tom tom  
13"x7.5" tom tom  
14"x12" floor tom  
16"x14" floor tom  
14"x6.5" snare drum



# INDIVIDUAL MODEL NUMBERS

Diameter	Depth	Model No.	
<b>Bass Drums</b>			
16"	12"	TBB1612S	10.064,00
18"	14"	TBB1814S	10.325,00
18"	15"	TBB1815S	10.325,00
18"	16"	TBB1816S	10.325,00
20"	14"	TBB2014S	10.715,00
20"	16"	TBB2016S	10.715,00
20"	17"	TBB2017S	10.715,00
20"	18"	TBB2018S	10.715,00
22"	14"	TBB2214S	11.280,00
22"	16"	TBB2216S	11.280,00
22"	17"	TBB2217S	11.280,00
22"	18"	TBB2218S	11.280,00
24"	14"	TBB2414S	11.887,00
24"	16"	TBB2416S	11.887,00
24"	17"	TBB2417S	11.887,00
24"	18"	TBB2418S	11.887,00
26"	14"	TBB2614S	12.885,00
26"	16"	TBB2616S	12.885,00
<b>Floor Toms</b>			
13"	12"	TBF1312S	5.681,00
14"	12"	TBF1412S	5.811,00
14"	13"	TBF1413S	5.811,00
14"	14"	TBF1414S	5.811,00
15"	13"	TBF1513S	6.158,00
15"	14"	TBF1514S	6.158,00
15"	15"	TBF1515S	6.158,00
16"	14"	TBF1614S	6.549,00
16"	15"	TBF1615S	6.549,00
16"	16"	TBF1616S	6.549,00
18"	14"	TBF1814S	6.896,00
18"	15"	TBF1815S	6.896,00
18"	16"	TBF1816S	6.896,00

Diameter	Depth	Model No.	
<b>Tom Toms</b>			
8"	6"	TBT0806S	3.641,00
8"	7"	TBT0807S	3.641,00
8"	8"	TBT0808S	3.641,00
10"	6.5"	TBT1065S	3.988,00
10"	7"	TBT1007S	3.988,00
10"	8"	TBT1008S	3.988,00
10"	9"	TBT1009S	3.988,00
10"	10"	TBT1010S	3.988,00
12"	7"	TBT1207S	4.509,00
12"	8"	TBT1208S	4.509,00
12"	9"	TBT1209S	4.509,00
12"	10"	TBT1210S	4.509,00
12"	11"	TBT1211S	4.509,00
13"	7.5"	TBT1375S	4.987,00
13"	9"	TBT1309S	4.987,00
13"	10"	TBT1310S	4.987,00
13"	11"	TBT1311S	4.987,00
13"	12"	TBT1312S	4.987,00
14"	8"	TBT1408S	5.507,00
14"	10"	TBT1410S	5.507,00
14"	11"	TBT1411S	5.507,00
14"	12"	TBT1412S	5.507,00
14"	13"	TBT1413S	5.507,00
<b>Snare Drums</b>			
13"	6"	TBS136S	4.683,00
14"	5.5"	TBS1455S	4.683,00
14"	6.5"	TBS1465S	4.683,00
14"	8"	TBS148S	4.683,00

\*Please ask price for "outside & inside inlay" option.

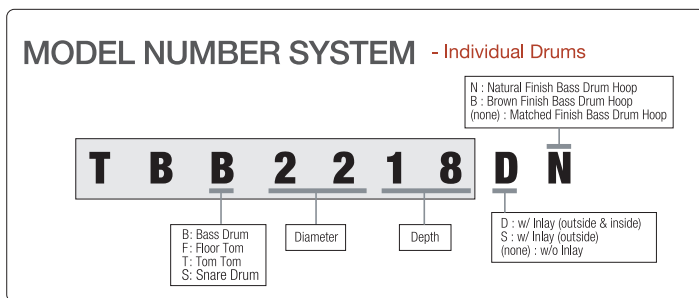

## SPECIFICATIONS

### Shells

5mm, 5ply Bubinga + 1 inner ply Cordia, or 5ply Bubinga + 1 outer ply Australian Acacia + 1 inner Ply Cordia for SAC/PBA, or 5ply Bubinga + 1 outer ply Indian Laurel + 1 inner ply Cordia for LNTI, or 4ply Bubinga + 1 outer & 1 inner ply Cordia for CDKG/CDKR, w/ 9mm Sound Focus Rings

### STAR Bearing Edges

Super Resonant Mounting System

Quick-Lock Tom Brackets

Minimum Shell Contact

STAR Floor Tom Legs

Hold Tight™ Washers

Remo® Drum Heads

## FINISHES (Lacquer)



Dark Green Cordia  
CDKG



Dark Red Cordia  
CDKR



Natural Indian Laurel  
LNTI



Pewter Blue Australian Acacia  
PBA



Sunset Australian Acacia Burst  
SAC



Satin Blue Metallic  
SBM



Antique White  
ATW

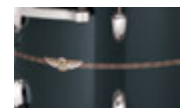

Smoky Black  
SKB



Atomic Orange  
AMO



Grand Aqua Blue  
GAQ



Solid Candy Red  
SDR



Piano Black  
PBK



Sunny Yellow Lacquer  
SYL

# TAMA STAR MAPLE

## Lacquer Finishes

STAR is the flagship line for TAMA drums. It takes the knowledge and research we cultivated for the Starclassic series to the next level, by reexamining every detail to enhance shell resonance. STAR Maple shell's "Solid Core Ply" is a totally new design for this series. This unique shell provides the warm, open tone of Maple, combined with the rich, hearty sound of a solid ply shell.



**COLOR** Emerald Sea Curly Maple Burst **RECB**

including:  
22"x16" bass drum  
8"x6" tom tom  
10"x7" tom tom  
12"x8" tom tom  
14"x14" floor tom  
16"x16" floor tom  
14"x6.5" snare drum



**COLOR** Gloss Natural Curly Maple **RGCM**

including:  
22"x16" bass drum  
8"x6" tom tom  
10"x7" tom tom  
12"x8" tom tom  
14"x14" floor tom  
16"x16" floor tom  
14"x6.5" snare drum



# INDIVIDUAL MODEL NUMBERS

Diameter	Depth	Model No.	
<b>Bass Drums</b>			
16"	12"	TMB1612S	10.064,00
18"	14"	TMB1814S	10.325,00
18"	15"	TMB1815S	10.325,00
18"	16"	TMB1816S	10.325,00
20"	14"	TMB2014S	10.715,00
20"	16"	TMB2016S	10.715,00
20"	17"	TMB2017S	10.715,00
20"	18"	TMB2018S	10.715,00
22"	14"	TMB2214S	11.280,00
22"	16"	TMB2216S	11.280,00
22"	17"	TMB2217S	11.280,00
22"	18"	TMB2218S	11.280,00
24"	14"	TMB2414S	11.887,00
24"	16"	TMB2416S	11.887,00
24"	17"	TMB2417S	11.887,00
24"	18"	TMB2418S	11.887,00
26"	14"	TMB2614S	12.885,00
26"	16"	TMB2616S	12.885,00
<b>Floor Toms</b>			
13"	12"	TMF1312S	5.681,00
14"	12"	TMF1412S	5.811,00
14"	13"	TMF1413S	5.811,00
14"	14"	TMF1414S	5.811,00
15"	13"	TMF1513S	6.158,00
15"	14"	TMF1514S	6.158,00
15"	15"	TMF1515S	6.158,00
16"	14"	TMF1614S	6.549,00
16"	15"	TMF1615S	6.549,00
16"	16"	TMF1616S	6.549,00
18"	14"	TMF1814S	6.896,00
18"	15"	TMF1815S	6.896,00
18"	16"	TMF1816S	6.896,00

Diameter	Depth	Model No.	
<b>Tom Toms</b>			
8"	6"	TMT0806S	3.641,00
8"	7"	TMT0807S	3.641,00
8"	8"	TMT0808S	3.641,00
10"	6.5"	TMT1065S	3.988,00
10"	7"	TMT1007S	3.988,00
10"	8"	TMT1008S	3.988,00
10"	9"	TMT1009S	3.988,00
10"	10"	TMT1010S	3.988,00
12"	7"	TMT1207S	4.509,00
12"	8"	TMT1208S	4.509,00
12"	9"	TMT1209S	4.509,00
12"	10"	TMT1210S	4.509,00
12"	11"	TMT1211S	4.509,00
13"	7.5"	TMT1375S	4.987,00
13"	9"	TMT1309S	4.987,00
13"	10"	TMT1310S	4.987,00
13"	11"	TMT1311S	4.987,00
13"	12"	TMT1312S	4.987,00
14"	8"	TMT1408S	5.507,00
14"	10"	TMT1410S	5.507,00
14"	11"	TMT1411S	5.507,00
14"	12"	TMT1412S	5.507,00
14"	13"	TMT1413S	5.507,00
<b>Snare Drums</b>			
13"	6"	TMS136S	4.683,00
14"	5.5"	TMS1455S	4.683,00
14"	6.5"	TMS1465S	4.683,00
14"	8"	TMS148S	4.683,00

\*Please ask price for "outside & inside inlay" option.

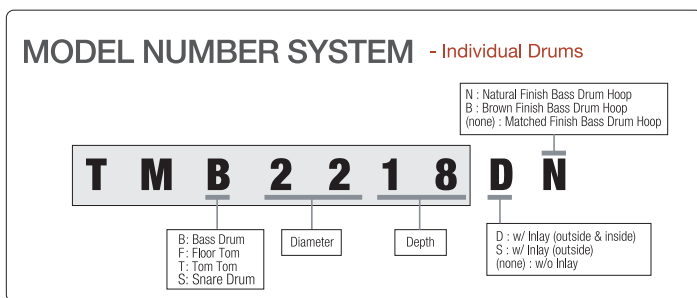

## SPECIFICATIONS

### Shells

5mm, 5ply Maple or 5ply Maple +1 outer ply Curly Maple for RGCM/RECB/ROLC/RRCM  
 w/ 5mm Sound Focus Rings

- STAR Bearing Edges
- Super Resonant Mounting System
- Quick-Lock Tom Brackets
- Minimum Shell Contact
- STAR Floor Tom Legs
- Hold Tight™ Washers
- Remo® Drum Heads

## FINISHES (Lacquer)



Gloss Natural Curly Maple  
RGCM



Emerald Sea Curly Maple Burst  
RECB

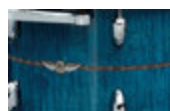

Ocean Blue Curly Maple  
ROLC



Raspberry Curly Maple  
RRCM



Satin Blue Metallic  
SBM



Satin Antique Brown  
SAB



Antique White  
ATW

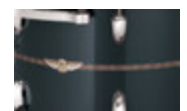

Smoky Black  
SKB

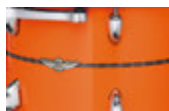

Atomic Orange  
AMO



Grand Aqua Blue  
GAQ



Solid Candy Red  
SDR



Piano Black  
PBK



Sunny Yellow Lacquer  
SYL

# TAMA STAR WALNUT

## Lacquer Finishes

STAR is the flagship line for TAMA drums. It takes the knowledge and research we cultivated for the Starclassic series to the next level, by reexamining every detail to enhance shell resonance. Walnut has long been favored by furniture makers for both its beauty and durability. As a drum shell material, Walnut's naturally EQ'ed tone has been praised by the drum community for both the stage and the studio. The STAR Walnut shells project booming low end with enough cut to be heard through any mix.



**COLOR** Antique White Japanese Chestnut **AWC**

### TW42RZS basic kit

including:

22"x16" bass drum

10"x7" tom tom

12"x8" tom tom

16"x16" floor tom

[add-on]

14"x6.5" snare drum

## KIT CONFIGURATIONS LIST

[22" BD 4pc Shell Kit]

**TW42RZS**

**17.790,00**

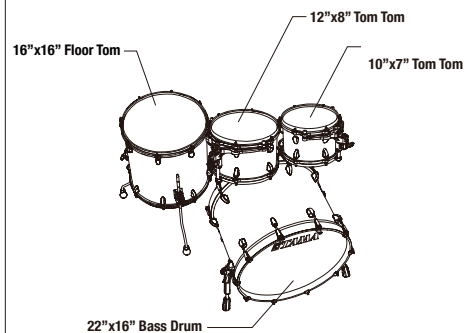



# INDIVIDUAL MODEL NUMBERS

Diameter	Depth	Model No.	
<b>Bass Drums</b>			
16"	12"	TWB1612	7.026,00
18"	14"	TWB1814	7.243,00
18"	15"	TWB1815	7.243,00
18"	16"	TWB1816	7.243,00
20"	14"	TWB2014	7.591,00
20"	16"	TWB2016	7.591,00
20"	17"	TWB2017	7.591,00
20"	18"	TWB2018	7.591,00
22"	14"	TWB2214	7.981,00
22"	16"	TWB2216	7.981,00
22"	17"	TWB2217	7.981,00
22"	18"	TWB2218	7.981,00
24"	14"	TWB2414	8.459,00
24"	16"	TWB2416	8.459,00
24"	17"	TWB2417	8.459,00
24"	18"	TWB2418	8.459,00
26"	14"	TWB2614	9.196,00
26"	16"	TWB2616	9.196,00
<b>Floor Toms</b>			
13"	12"	TWF1312	3.988,00
14"	12"	TWF1412	4.075,00
14"	13"	TWF1413	4.075,00
14"	14"	TWF1414	4.075,00
15"	13"	TWF1513	4.379,00
15"	14"	TWF1514	4.379,00
15"	15"	TWF1515	4.379,00
16"	14"	TWF1614	4.596,00
16"	15"	TWF1615	4.596,00
16"	16"	TWF1616	4.596,00
18"	14"	TWF1814	4.943,00
18"	15"	TWF1815	4.943,00
18"	16"	TWF1816	4.943,00

Diameter	Depth	Model No.	
<b>Tom Toms</b>			
8"	6"	TWT0806	2.556,00
8"	7"	TWT0807	2.556,00
8"	8"	TWT0808	2.556,00
10"	6.5"	TWT1065	2.817,00
10"	7"	TWT1007	2.817,00
10"	8"	TWT1008	2.817,00
10"	9"	TWT1009	2.817,00
10"	10"	TWT1010	2.817,00
12"	7"	TWT1207	3.164,00
12"	8"	TWT1208	3.164,00
12"	9"	TWT1209	3.164,00
12"	10"	TWT1210	3.164,00
12"	11"	TWT1211	3.164,00
13"	7.5"	TWT1375	3.468,00
13"	9"	TWT1309	3.468,00
13"	10"	TWT1310	3.468,00
13"	11"	TWT1311	3.468,00
13"	12"	TWT1312	3.468,00
14"	8"	TWT1408	3.858,00
14"	10"	TWT1410	3.858,00
14"	11"	TWT1411	3.858,00
14"	12"	TWT1412	3.858,00
14"	13"	TWT1413	3.858,00
<b>Snare Drums</b>			
13"	6"	TWS136	3.294,00
14"	5.5"	TWS1455	3.294,00
14"	6.5"	TWS1465	3.294,00
14"	8"	TWS148	3.294,00

## MODEL NUMBER SYSTEM - Individual Drums

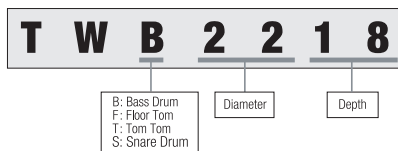

## SPECIFICATIONS

### Shells

All Walnut Shell TT/FT/SD: 6mm 6ply, BD: 7mm 7ply (except AUB, AGJB, ASBJ, ASCS, LIC, AWC, RSC)

\*AUB, AGJB, ASBJ, ASCS

TT/FT/SD: 6mm, 4ply Walnut + 2 outer ply Japanese Sen

BD: 7mm, 5ply Walnut + 2 outer ply Japanese Sen

\*LIC, AWC, RSC

TT/FT/SD: 6mm, 5ply Walnut + 1 outer ply Japanese Chestnut

BD: 7mm, 6ply Walnut + 1 outer ply Japanese Chestnut

STAR Bearing Edges

Super Resonant Mounting System

Quick-Lock Tom Brackets

Minimum Shell Contact

STAR Floor Tom Legs

Remo® Drum Heads

## FINISHES (Lacquer)

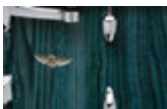

Light Indigo Japanese Chestnut  
**LIC**



Roasted Japanese Chestnut  
**RSC**



Antique White Japanese Chestnut  
**AWC**



Indigo Japanese Sen Burst  
**AJJB**



Garnet Japanese Sen Burst  
**AGJB**



Satin Black Japanese Sen Burst  
**ASBJ**



Satin Charcoal Japanese Sen  
**ASCS**

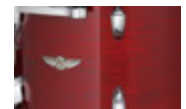

Red Burgundy Walnut  
**RBW**

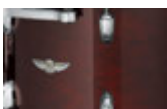

Dark Mocha Walnut  
**DMW**

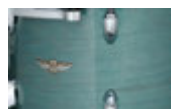

Smoky Blue Mist  
**SBU**

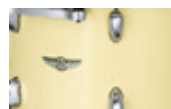

Antique White  
**ATW**

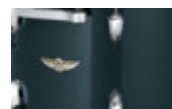

Smoky Black  
**SKB**

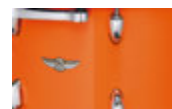

Atomic Orange  
**AMO**

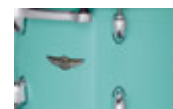

Grand Aqua Blue  
**GAQ**



Solid Candy Red  
**SDR**



Piano Black  
**PBW**

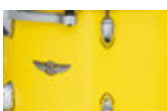

Sunny Yellow Lacquer  
**SYL**

# STARCLASSIC MAPLE

## Exotic Finishes

In the '80s TAMA's Superstars and Imperialstars reigned supreme - the perfect drums for the times. But TAMA's builders and designers wanted something that transcended trends, something timeless - drums that understood a player's passion and allowed the expression of every genre, style, mood, and technique. They created Starclassic Maple drums...and ignited the thin-shell revolution. And now the Exotic Finish line offers beautiful, one-of-a-kind exotic wood exteriors for that extra luxurious touch.

Numerous options are available to meet the varied and critical needs of professional drummers including a selection of about 30 different shell sizes. Starclassic Maple also features three shell hardware finishes to choose from: Black Nickel, Chrome and Smoked Black Nickel. Starclassic Maple is simply an unprecedented combination of sight and sound.



**COLOR** Tobacco Sunburst Movingui VTBV  
w/ smoked black nickel hardware

### ME42TZUS basic kit

including:

- 22"x16" bass drum
- 10"x7" tom tom
- 12"x8" tom tom
- 16"x16" floor tom

[add-on]

- 14"x6.5" snare drum

## KIT CONFIGURATIONS LIST

### [22" BD 3pc Shell Kit]

ME32CZS	w/ Chrome Hardware	13.016,00
ME32CZBS	w/ Black Nickel Hardware	13.016,00
ME32CZUS	w/ Smoked Black Nickel Hardware	13.016,00

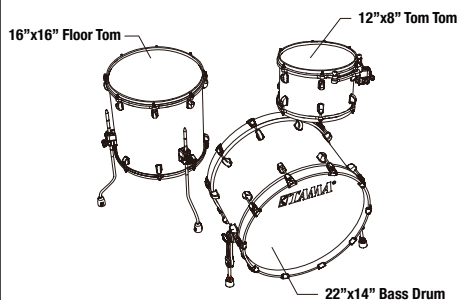

### [22" BD 4pc Shell Kit]

ME42TZS	w/ Chrome Hardware	15.186,00
ME42TZBS	w/ Black Nickel Hardware	15.186,00
ME42TZUS	w/ Smoked Black Nickel Hardware	15.186,00

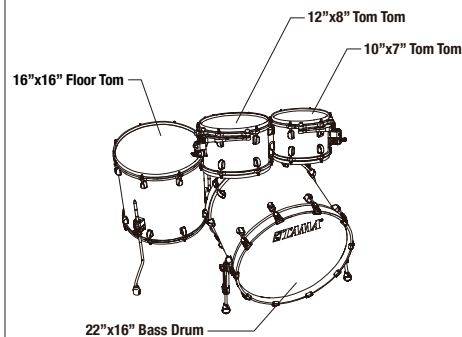



# INDIVIDUAL MODEL NUMBERS

Diameter	Depth	Model No.			
		Black Nickel	Chrome	Smoked Black Nickel	
<b>Bass Drums</b> *To order Bass Drum w/ Tom Holder Base, Please substitute "Z" with "M". Ex MEB2218Z → MEB2218M					
16"	12"	MEB1612ZB	MEB1612Z	MEB1612ZU	6.028,00
18"	14"	MEB1814ZB	MEB1814Z	MEB1814ZU	6.336,00
20"	14"	MEB2014ZB	MEB2014Z	MEB2014ZU	6.532,00
20"	16"	MEB2016ZB	MEB2016Z	MEB2016ZU	6.532,00
22"	14"	MEB2214ZB	MEB2214Z	MEB2214ZU	6.801,00
22"	16"	MEB2216ZB	MEB2216Z	MEB2216ZU	6.801,00
22"	18"	MEB2218ZB	MEB2218Z	MEB2218ZU	6.961,00
24"	14"	MEB2414ZB	MEB2414Z	MEB2414ZU	7.144,00
24"	16"	MEB2416ZB	MEB2416Z	MEB2416ZU	7.144,00
<b>Floor Toms</b>					
13"	12"	MEF1312B	MEF1312	MEF1312U	3.598,00
14"	12"	MEF1412B	MEF1412	MEF1412U	3.789,00
14"	14"	MEF1414B	MEF1414	MEF1414U	3.789,00
16"	14"	MEF1614B	MEF1614	MEF1614U	4.175,00
16"	16"	MEF1616B	MEF1616	MEF1616U	4.175,00
18"	16"	MEF1816B	MEF1816	MEF1816U	4.592,00
<b>Tom Toms</b>					
8"	6"	MET0806B	MET0806	MET0806U	2.305,00
8"	7"	MET0807B	MET0807	MET0807U	2.305,00
10"	6.5"	MET1065B	MET1065	MET1065U	2.522,00
10"	7"	MET1007B	MET1007	MET1007U	2.522,00
10"	8"	MET1008B	MET1008	MET1008U	2.522,00
10"	9"	MET1009B	MET1009	MET1009U	2.522,00
12"	7"	MET1207B	MET1207	MET1207U	2.830,00
12"	8"	MET1208B	MET1208	MET1208U	2.830,00
12"	9"	MET1209B	MET1209	MET1209U	2.830,00
12"	10"	MET1210B	MET1210	MET1210U	2.830,00
13"	7.5"	MET1375B	MET1375	MET1375U	3.199,00
13"	9"	MET1309B	MET1309	MET1309U	3.199,00
13"	10"	MET1310B	MET1310	MET1310U	3.199,00
13"	11"	MET1311B	MET1311	MET1311U	3.199,00
14"	10"	MET1410B	MET1410	MET1410U	3.515,00
14"	11"	MET1411B	MET1411	MET1411U	3.515,00
14"	12"	MET1412B	MET1412	MET1412U	3.515,00
<b>Snare Drums</b>					
13"	6"	MES136B	MES136	MES136U	2.686,00
14"	5.5"	MES1455B	MES1455	MES1455U	2.686,00
14"	6.5"	MES1465B	MES1465	MES1465U	2.773,00
14"	8"	MES148B	MES148	MES148U	3.294,00

# SPECIFICATIONS

## Shells

(LEWB/LNWB/LRWB)  
 TT/FT: 5mm, 6ply Maple + 1 outer ply Pacific Walnut  
 BD/SD: 7mm, 8ply Maple + 1 outer ply Pacific Walnut

## (VGLM/VTBV)

TT/FT: 5mm, 6ply Maple + 1 outer ply Movingui  
 BD/SD: 7mm, 8ply Maple + 1 outer ply Movingui

- Star-Cast Mounting System
- Quick-Lock Tom Bracket
- EVANS® Heads
- Die-Cast Hoops
- Hold Tight™ Washers
- Claw Hooks w/ Rubber Spacers
- Cushioned Floor Tom Legs

# OPTION



## MODEL NUMBER SYSTEM - Individual Drums

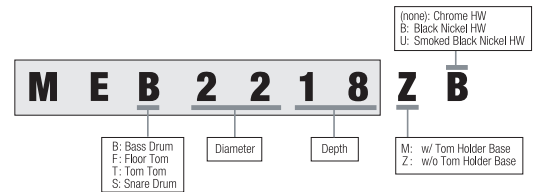

# FINISHES (Lacquer)



Tobacco Sunburst Movingui  
**VTBV**



Gloss Natural Movingui  
**VGLM**



Ruby Pacific Walnut Burst  
**LRWB**



Emerald Pacific Walnut Burst  
**LEWB**



Natural Pacific Walnut Burst  
**LNWB**

# STARCLASSIC MAPLE

Lacquer Finishes



**COLOR** Molten Electric Blue Burst **MEB**  
w/ black nickel hardware

## MA42TZBNS basic kit

including:

- 22"x16" bass drum
- 10"x7" tom tom
- 12"x8" tom tom
- 16"x16" floor tom

[add-on]

- 14"x6.5" snare drum

## KIT CONFIGURATIONS LIST

### [22" BD 3pc Shell Kit]

<b>MA32CZS</b>	w/ Chrome Hardware	<b>13.016,00</b>
<b>MA32CZBNS</b>	w/ Black Nickel Hardware	<b>13.016,00</b>
<b>MA32CZUS</b>	w/ Smoked Black Nickel Hardware	<b>13.016,00</b>

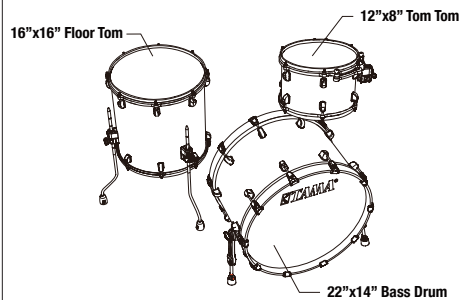

### [22" BD 4pc Shell Kit]

<b>MA42TZS</b>	w/ Chrome Hardware	<b>15.186,00</b>
<b>MA42TZBNS</b>	w/ Black Nickel Hardware	<b>15.186,00</b>
<b>MA42TZUS</b>	w/ Smoked Black Nickel Hardware	<b>15.186,00</b>

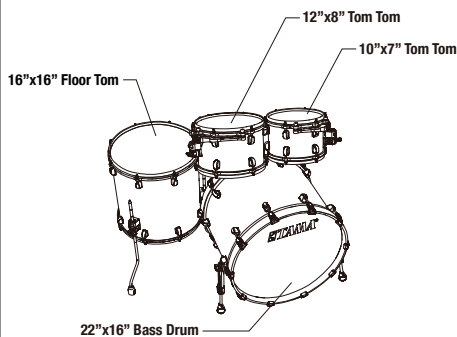

# INDIVIDUAL MODEL NUMBERS

Diameter	Depth	Model No.			
		Black Nickel	Chrome	Smoked Black Nickel	
<b>Bass Drum</b>					
*To order Bass Drum w/ Tom Holder Base, Please substitute "Z" with "M". Ex MAB2218Z → MAB2218M					
16"	12"	MAB1612ZBN	MAB1612Z	MAB1612ZU	6,028,00
18"	14"	MAB1814ZBN	MAB1814Z	MAB1814ZU	6,336,00
20"	14"	MAB2014ZBN	MAB2014Z	MAB2014ZU	6,532,00
20"	16"	MAB2016ZBN	MAB2016Z	MAB2016ZU	6,532,00
22"	14"	MAB2214ZBN	MAB2214Z	MAB2214ZU	6,801,00
22"	16"	MAB2216ZBN	MAB2216Z	MAB2216ZU	6,801,00
22"	18"	MAB2218ZBN	MAB2218Z	MAB2218ZU	6,961,00
24"	14"	MAB2414ZBN	MAB2414Z	MAB2414ZU	7,144,00
24"	16"	MAB2416ZBN	MAB2416Z	MAB2416ZU	7,144,00
<b>Floor Toms</b>					
13"	12"	MAF1312BN	MAF1312	MAF1312U	3,598,00
14"	12"	MAF1412BN	MAF1412	MAF1412U	3,789,00
14"	14"	MAF1414BN	MAF1414	MAF1414U	3,789,00
16"	14"	MAF1614BN	MAF1614	MAF1614U	4,175,00
16"	16"	MAF1616BN	MAF1616	MAF1616U	4,175,00
18"	16"	MAF1816BN	MAF1816	MAF1816U	4,592,00
<b>Tom Toms</b>					
8"	6"	MAT0806BN	MAT0806	MAT0806U	2,305,00
8"	7"	MAT0807BN	MAT0807	MAT0807U	2,305,00
10"	6.5"	MAT1065BN	MAT1065	MAT1065U	2,522,00
10"	7"	MAT1007BN	MAT1007	MAT1007U	2,522,00
10"	8"	MAT1008BN	MAT1008	MAT1008U	2,522,00
10"	9"	MAT1009BN	MAT1009	MAT1009U	2,522,00
12"	7"	MAT1207BN	MAT1207	MAT1207U	2,830,00
12"	8"	MAT1208BN	MAT1208	MAT1208U	2,830,00
12"	9"	MAT1209BN	MAT1209	MAT1209U	2,830,00
12"	10"	MAT1210BN	MAT1210	MAT1210U	2,830,00
13"	7.5"	MAT1375BN	MAT1375	MAT1375U	3,199,00
13"	9"	MAT1309BN	MAT1309	MAT1309U	3,199,00
13"	10"	MAT1310BN	MAT1310	MAT1310U	3,199,00
13"	11"	MAT1311BN	MAT1311	MAT1311U	3,199,00
14"	10"	MAT1410BN	MAT1410	MAT1410U	3,515,00
14"	11"	MAT1411BN	MAT1411	MAT1411U	3,515,00
14"	12"	MAT1412BN	MAT1412	MAT1412U	3,515,00
<b>Snare Drums</b>					
13"	6"	MAS136BN	MAS136	MAS136U	2,686,00
14"	5.5"	MAS1455BN	MAS1455	MAS1455U	2,686,00
14"	6.5"	MAS1465BN	MAS1465	MAS1465U	2,773,00
14"	8"	MAS148BN	MAS148	MAS148U	3,294,00

# SPECIFICATIONS

## Shells

All Maple Shell  
 TT/FT: 5mm, 6ply  
 BD/SD: 7mm, 8ply

- Star-Cast Mounting System
- Quick-Lock Tom Bracket
- EVANS® Heads
- Die-Cast Hoops
- Hold Tight™ Washers
- Claw Hooks w/ Rubber Spacers
- Cushioned Floor Tom Legs

# OPTION



## MODEL NUMBER SYSTEM - Individual Drums

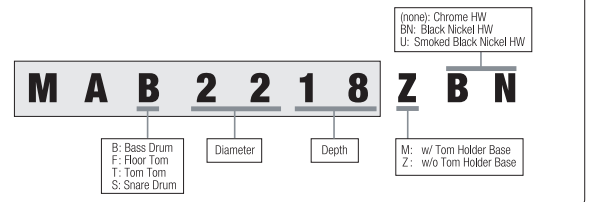

# FINISHES (Lacquer)

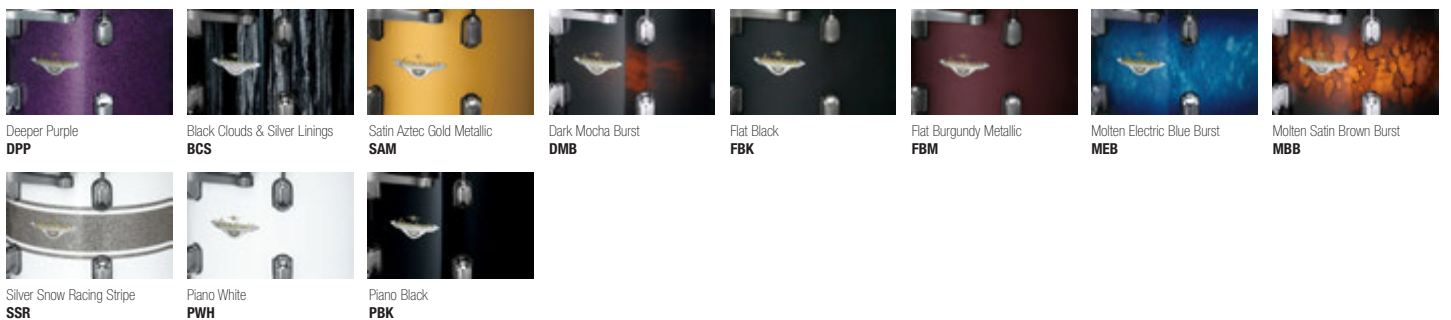



# STARCLASSIC MAPLE

Duracover Wrap Finishes



**COLOR** Red Oyster  
w/ black nickel hardware

**ROY**

## MR42TZBNS basic kit

including:

22"x16" bass drum  
10"x7" tom tom  
12"x8" tom tom  
16"x16" floor tom

[add-on]

14"x6.5" snare drum

## KIT CONFIGURATIONS LIST

### [22" BD 3pc Shell Kit]

MR32CZS	w/ Chrome Hardware	12.148,00
MR32CZBNS	w/ Black Nickel Hardware	12.148,00
MR32CZUS	w/ Smoked Black Nickel Hardware	12.148,00

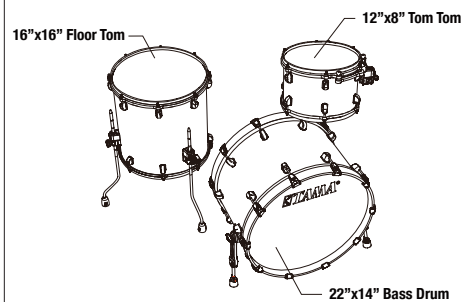

### [22" BD 4pc Shell Kit]

MR42TZS	w/ Chrome Hardware	14.318,00
MR42TZBNS	w/ Black Nickel Hardware	14.318,00
MR42TZUS	w/ Smoked Black Nickel Hardware	14.318,00

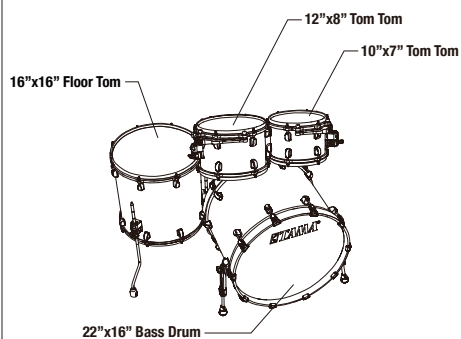

# INDIVIDUAL MODEL NUMBERS

Diameter	Depth	Model No.			
		Black Nickel	Chrome	Smoked Black Nickel	
<b>Bass Drum</b> *To order Bass Drum w/ Tom Holder Base, Please substitute "Z" with "M". Ex MRB2218Z → MRB2218M					
16"	12"	MRB1612ZBN	MRB1612Z	MRB1612ZU	5.555,00
18"	14"	MRB1814ZBN	MRB1814Z	MRB1814ZU	5.833,00
20"	14"	MRB2014ZBN	MRB2014Z	MRB2014ZU	6.011,00
20"	16"	MRB2016ZBN	MRB2016Z	MRB2016ZU	6.011,00
22"	14"	MRB2214ZBN	MRB2214Z	MRB2214ZU	6.263,00
22"	16"	MRB2216ZBN	MRB2216Z	MRB2216ZU	6.263,00
22"	18"	MRB2218ZBN	MRB2218Z	MRB2218ZU	6.415,00
24"	14"	MRB2414ZBN	MRB2414Z	MRB2414ZU	6.575,00
24"	16"	MRB2416ZBN	MRB2416Z	MRB2416ZU	6.575,00
<b>Floor Toms</b>					
13"	12"	MRF1312BN	MRF1312	MRF1312U	3.311,00
14"	12"	MRF1412BN	MRF1412	MRF1412U	3.498,00
14"	14"	MRF1414BN	MRF1414	MRF1414U	3.498,00
16"	14"	MRF1614BN	MRF1614	MRF1614U	3.845,00
16"	16"	MRF1616BN	MRF1616	MRF1616U	3.845,00
18"	16"	MRF1816BN	MRF1816	MRF1816U	4.223,00
<b>Tom Toms</b>					
8"	6"	MRT0806BN	MRT0806	MRT0806U	2.122,00
8"	7"	MRT0807BN	MRT0807	MRT0807U	2.122,00
10"	6.5"	MRT1065BN	MRT1065	MRT1065U	2.318,00
10"	7"	MRT1007BN	MRT1007	MRT1007U	2.318,00
10"	8"	MRT1008BN	MRT1008	MRT1008U	2.318,00
10"	9"	MRT1009BN	MRT1009	MRT1009U	2.318,00
12"	7"	MRT1207BN	MRT1207	MRT1207U	2.604,00
12"	8"	MRT1208BN	MRT1208	MRT1208U	2.604,00
12"	9"	MRT1209BN	MRT1209	MRT1209U	2.604,00
12"	10"	MRT1210BN	MRT1210	MRT1210U	2.604,00
13"	7.5"	MRT1375BN	MRT1375	MRT1375U	2.947,00
13"	9"	MRT1309BN	MRT1309	MRT1309U	2.947,00
13"	10"	MRT1310BN	MRT1310	MRT1310U	2.947,00
13"	11"	MRT1311BN	MRT1311	MRT1311U	2.947,00
14"	10"	MRT1410BN	MRT1410	MRT1410U	3.238,00
14"	11"	MRT1411BN	MRT1411	MRT1411U	3.238,00
14"	12"	MRT1412BN	MRT1412	MRT1412U	3.238,00
<b>Snare Drums</b>					
13"	6"	MRS136BN	MRS136	MRS136U	2.469,00
14"	5.5"	MRS1455BN	MRS1455	MRS1455U	2.469,00
14"	6.5"	MRS1465BN	MRS1465	MRS1465U	2.556,00
14"	8"	MRS148BN	MRS148	MRS148U	3.077,00

# SPECIFICATIONS

Shells  
All Maple Shell  
TT/FT: 5mm, 6ply  
BD/SD: 7mm, 8ply

Star-Cast Mounting System  
Quick-Lock Tom Bracket  
EVANS® Heads  
Die-Cast Hoops  
Hold Tight™ Washers  
Claw Hooks w/ Rubber Spacers  
Cushioned Floor Tom Legs

# OPTION



Chrome HW



Black Nickel HW



Smoked Black Nickel HW

## MODEL NUMBER SYSTEM - Individual Drums

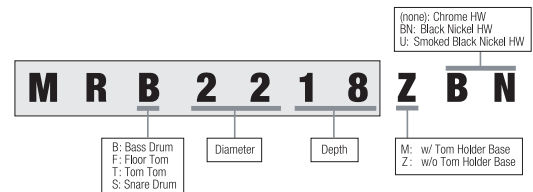

# FINISHES (Duracover Wrap)



Blue and White Oyster  
**BWO**



Red Oyster  
**ROY**



Charcoal Swirl  
**CCL**



Sky Blue Swirl  
**SLW**



Turquoise Pearl  
**TQP**

# STARCLASSIC WALNUT/BIRCH

## Lacquer Finishes

Exploring limitless possibilities, our result in the wake of countless experimentation came in the form of the Hybrid Shell Walnut/Birch: combining the superior quality warmth and mid to low frequency tone of the increasingly popular and truly unique Walnut, with the well-defined and uncompromisingly solid attack of Birch.

Whilst we successfully preserved their unique sonic trademarks, the characteristics of both Walnut and Birch blend to persuade a very focused sound that would define itself with great distinction within a musical ensemble; married with controlled sustain and clarity; all sealed with an undeniably palpable feeling of warmth and resonance when performed.



**COLOR** Molten Blue Ice Fade

**MBI**

### WBS52RZS basic kit

including:

- 22"x16" bass drum
- 10"x7" tom tom
- 12"x8" tom tom
- 14"x12" floor tom
- 16"x14" floor tom
- MC69 single tom attachments (x2)

[add-on]

- 14"x6.5" snare drum

## KIT CONFIGURATIONS LIST

### [20" BD 3pc Shell Kit]

**WBS30RS** w/ Chrome Hardware 8.025,00

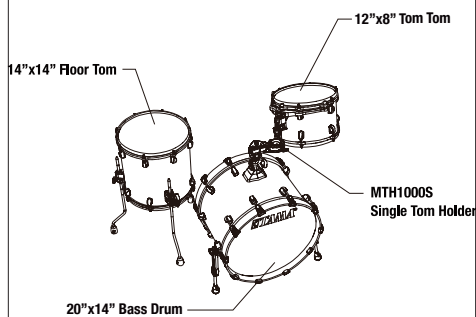

### [22" BD 3pc Shell Kit]

**WBS32RZS** w/ Chrome Hardware 8.025,00

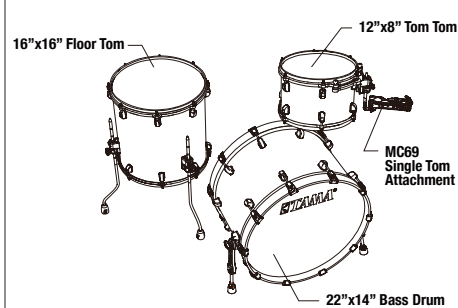

### [22" BD 4pc Shell Kit]

**WBS42S** w/ Chrome Hardware 9.978,00

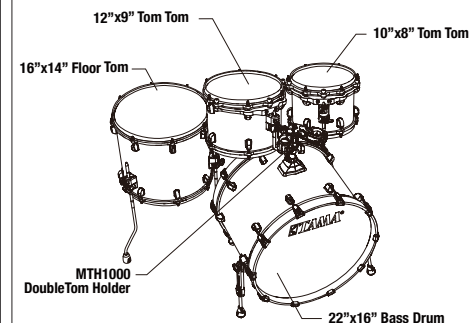

### [22" BD 5pc Shell Kit]

**WBS52RZS** w/ Chrome Hardware 12.582,00

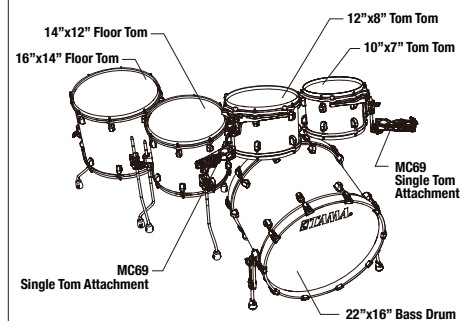



# INDIVIDUAL MODEL NUMBERS

Diameter	Depth	Model No.	
<b>Bass Drums</b>			
16"	12"	WBSB16HZ	5.204,00
18"	14"	WBSB18RZ	5.481,00
20"	14"	WBSB20RZ	5.690,00
20"	16"	WBSB20DZ	5.690,00
22"	14"	WBSB22RZ	5.985,00
22"	16"	WBSB22DZ	5.985,00
22"	18"	WBSB22EZ	6.328,00
24"	16"	WBSB24DZ	6.419,00
<b>Floor Toms</b>			
13"	12"	WBSF13R	2.847,00
14"	12"	WBSF14A	2.995,00
14"	14"	WBSF14D	2.995,00
16"	14"	WBSF16A	3.194,00
16"	16"	WBSF16D	3.194,00
18"	16"	WBSF18D	3.515,00
<b>Tom Toms</b>			
8"	6"	WBST8H	1.897,00
8"	7"	WBST8A	1.897,00
10"	6.5"	WBST10H	2.057,00
10"	7"	WBST10R	2.057,00
10"	8"	WBST10A	2.057,00
12"	7"	WBST12H	2.296,00
12"	8"	WBST12R	2.296,00
12"	9"	WBST12A	2.296,00
13"	7.5"	WBST13H	2.591,00
13"	9"	WBST13R	2.591,00
13"	10"	WBST13A	2.591,00
14"	11"	WBST14A	2.834,00
14"	12"	WBST14D	2.834,00
<b>Snare Drums</b>			
13"	6"	WBSS136	1.949,00
14"	5.5"	WBSS55	1.992,00
14"	6.5"	WBSS65	2.035,00
14"	8"	WBSS148	2.339,00

## MODEL NUMBER SYSTEM - Individual Drums

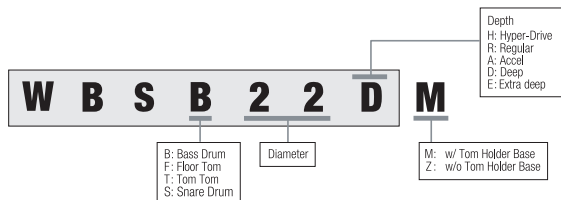

## SPECIFICATIONS

### Shells

TT/FT/SD: 6mm, 4ply European Birch + 2 inner ply American Black Walnut  
 BD: 8mm, 5ply European Birch + 2 inner ply American Black Walnut

Star-Cast Mounting System

Quick-Lock Tom Bracket

EVANS® Heads

Claw Hooks w/ Rubber Spacers

Cushioned Floor Tom Legs

Die-Cast Hoops

## FINISHES (Lacquer)



Lacquer Ocean Blue Ripple  
**LOR**



Lacquer Phantasm Oyster  
**LPO**



Lacquer Shamrock Oyster  
**LSO**



Satin Purple Atmosphere Fade  
**SAF**



Satin Sapphire Fade  
**SPF**



Molten Blue Ice Fade  
**MBI**



Molten Dark Raspberry Fade  
**MDR**



Molten Brown Burst  
**MBR**



Piano Black  
**PBK**

# STARCLASSIC WALNUT/BIRCH

Duracover Wrap Finishes



**COLOR** Turquoise Pearl **TQP**

## WBR32RZS basic kit

including:  
 22"x14" bass drum  
 12"x8" tom tom  
 16"x16" floor tom  
 MC69 single tom attachment

[add-on]  
 14"x6.5" snare drum

## KIT CONFIGURATIONS LIST

[20" BD 3pc Shell Kit]

**WBR30RS** w/ Chrome Hardware **8.025,00**

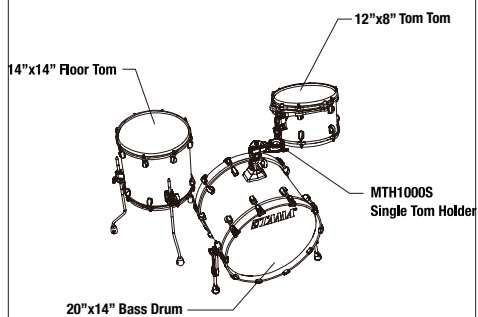

[22" BD 3pc Shell Kit]

**WBR32RZS** w/ Chrome Hardware **8.025,00**

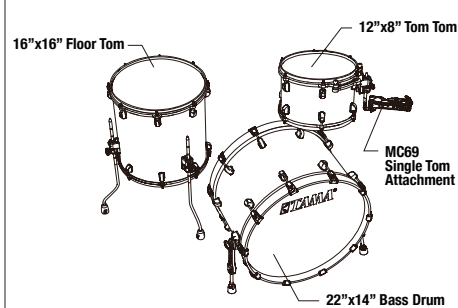

[22" BD 4pc Shell Kit]

**WBR42S** w/ Chrome Hardware **9.978,00**

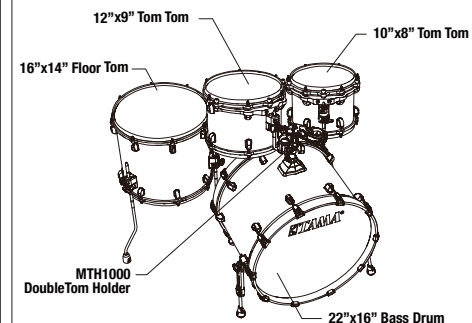

[22" BD 5pc Shell Kit]

**WBR52RZS** w/ Chrome Hardware **12.582,00**

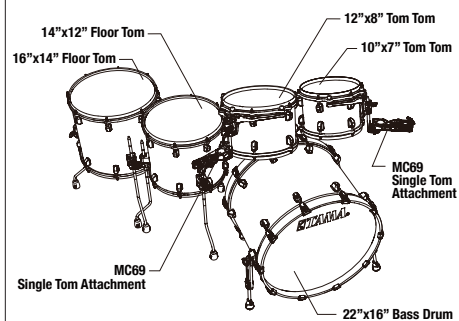



# INDIVIDUAL MODEL NUMBERS

Diameter	Depth	Model No.		
<b>Bass Drums</b> *To order Bass Drum w/ Tom Holder Base, Please substitute "Z" with "M". Ex WBRB22DZ → WBRB22DM				
16"	12"	WBRB16HZ		5.204,00
18"	14"	WBRB18RZ		5.481,00
20"	14"	WBRB20RZ		5.690,00
20"	16"	WBRB20DZ		5.690,00
22"	14"	WBRB22RZ		5.985,00
22"	16"	WBRB22DZ		5.985,00
22"	18"	WBRB22EZ		6.328,00
24"	16"	WBRB24DZ		6.419,00
<b>Floor Toms</b>				
13"	12"	WBRF13R		2.847,00
14"	12"	WBRF14A		2.995,00
14"	14"	WBRF14D		2.995,00
16"	14"	WBRF16A		3.194,00
16"	16"	WBRF16D		3.194,00
18"	16"	WBRF18D		3.515,00
<b>Tom Toms</b>				
8"	6"	WBRT8H		1.897,00
8"	7"	WBRT8A		1.897,00
10"	6.5"	WBRT10H		2.057,00
10"	7"	WBRT10R		2.057,00
10"	8"	WBRT10A		2.057,00
12"	7"	WBRT12H		2.296,00
12"	8"	WBRT12R		2.296,00
12"	9"	WBRT12A		2.296,00
13"	7.5"	WBRT13H		2.591,00
13"	9"	WBRT13R		2.591,00
13"	10"	WBRT13A		2.591,00
14"	11"	WBRT14A		2.834,00
14"	12"	WBRT14D		2.834,00
<b>Snare Drums</b>				
13"	6"	WBRS136		1.949,00
14"	5.5"	WBRS55		1.992,00
14"	6.5"	WBRS65		2.035,00
14"	8"	WBRS148		2.339,00

## MODEL NUMBER SYSTEM - Individual Drums

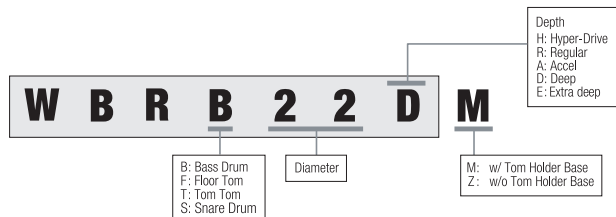

## SPECIFICATIONS

### Shells

TT/FT/SD: 6mm, 4ply European Birch + 2 inner ply American Black Walnut  
 BD: 8mm, 5ply European Birch + 2 inner ply American Black Walnut

Star-Cast Mounting System    Claw Hooks w/ Rubber Spacers  
 Quick-Lock Tom Bracket        Cushioned Floor Tom Legs  
 EVANS® Heads                    Die-Cast Hoops

## FINISHES (Duracover Wrap)

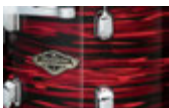

Red Oyster  
ROY



Vintage Marine Pearl  
VMP



Turquoise Pearl  
TQP



Charcoal Onyx  
CCO

# STARCLASSIC PERFORMER

## Lacquer Finishes

Tama's newest Starclassic Performer series centers on the newest Tama hybrid shell – maple/birch – to offer drummers a complex, powerful and expressive sound supported by rugged Starclassic performance. Tama's Starclassic Performer series evolves the Starclassic legacy to provide a unique Tama sonic component that redefines the art of professional drum set sound and expression at an undeniable value.



**COLOR** Sky Blue Aurora

**SKA**

### MBS52RZS basic kit

including:  
 22"x16" bass drum  
 10"x7" tom tom  
 12"x8" tom tom  
 14"x12" floor tom  
 16"x14" floor tom  
 MC69 single tom attachments (x2)

[add-on]  
 14"x6.5" snare drum

## KIT CONFIGURATIONS LIST

[22" BD 4pc Shell Kit]

**MBS42S** w/ Chrome Hardware

6.506,00

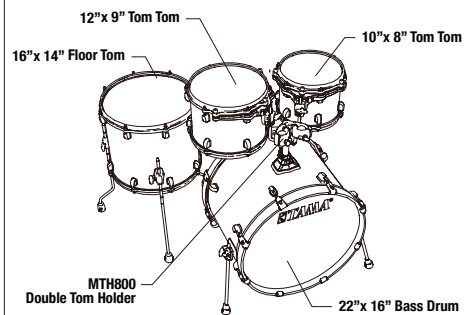

[22" BD 5pc Shell Kit]

**MBS52RZS** w/ Chrome Hardware

7.808,00

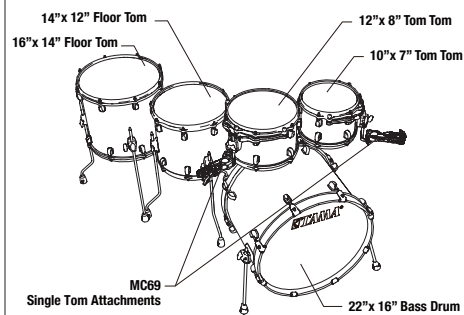

# INDIVIDUAL MODEL NUMBERS

Diameter	Depth	Model No.	
<b>Bass Drums</b> *To order Bass Drum w/ Tom Holder Base, Please substitute "Z" with "M". Ex MBSB22DZ → MBSB22DM			
18"	14"	MBSB18RZ	3.494,00
20"	14"	MBSB20RZ	3.633,00
22"	16"	MBSB22DZ	3.815,00
22"	18"	MBSB22EZ	4.045,00
24"	16"	MBSB24DZ	4.275,00
<b>Floor Toms</b>			
14"	12"	MBSF14A	2.161,00
14"	14"	MBSF14D	2.161,00
16"	14"	MBSF16A	2.391,00
18"	16"	MBSF18D	2.621,00
<b>Tom Toms</b>			
8"	6"	MBST8H	1.332,00
8"	7"	MBST8A	1.332,00
10"	7"	MBST10R	1.471,00
10"	8"	MBST10A	1.471,00
12"	8"	MBST12R	1.606,00
12"	9"	MBST12A	1.606,00
13"	9"	MBST13R	1.884,00
13"	10"	MBST13A	1.884,00
<b>Snare Drums</b>			
14"	5.5"	MBSS55	1.428,00
14"	6.5"	MBSS65	1.471,00

## MODEL NUMBER SYSTEM - Individual Drums

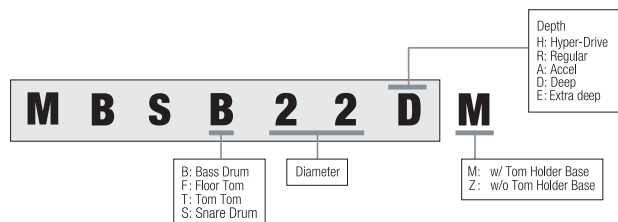

## SPECIFICATIONS

### Shells

TT/FT/SD: 6mm, 4ply Birch + 2 inner ply Maple  
BD: 7mm, 5ply Birch + 2 inner ply Maple

Star-Cast Mounting System

Claw Hooks w/ Rubber Spacers

Cushioned Floor Tom Legs

EVANS® Heads

Die-Cast Hoops

## FINISHES (Lacquer)



Caramel Aurora  
CAR



Sky Blue Aurora  
SKA



Molten Steel Blue Burst  
MSL



Dark Cherry Fade  
DCF



Piano Black  
PBK



# SUPERSTAR CLASSIC

## Exotic Finishes

For more than forty years, the Superstar name has stood for groundbreaking design, superior build quality, sterling tone, and clear projection. Superstar Classic once again upholds tradition by raising the bar for discerning drummers—and remarkably—does it while also lowering the price. Drawing on Superstar of the past, its classic TAMA T-shape badge and streamlined low-mass single lugs point to the simpler state of art of the 70's, while the ingenious Star-Mount system and the thinner gauge 100% maple shells eclipse anything in its class.



**COLOR** Caribbean Lacedbark Pine Fade **PCLP**

### CL72RS 7pc basic kit

including:  
 22"x16" bass drum  
 8"x6" tom tom  
 10"x7" tom tom  
 12"x8" tom tom  
 14"x12" floor tom  
 16"x14" floor tom  
 14"x6.5" snare drum  
 MTH600 double tom holder  
 MC69 single tom attachment

## KIT CONFIGURATIONS LIST

### [22" BD 5pc Shell Kit]

<b>CL52KRS</b>		<b>4.553,00</b>
<b>CL52KR</b>	w/SM5W hardware pack	<b>5.724,00</b>

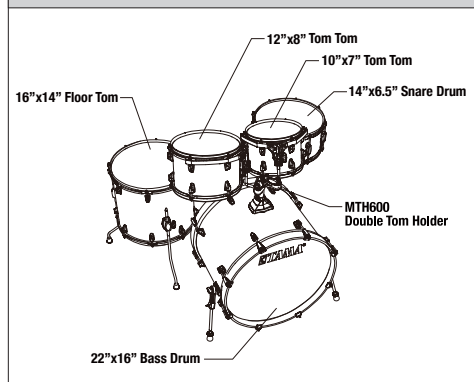

### [22" BD 7pc Shell Kit]

<b>CL72RS</b>		<b>6.636,00</b>
<b>CL72R</b>	w/ SM5W hardware pack	<b>7.808,00</b>

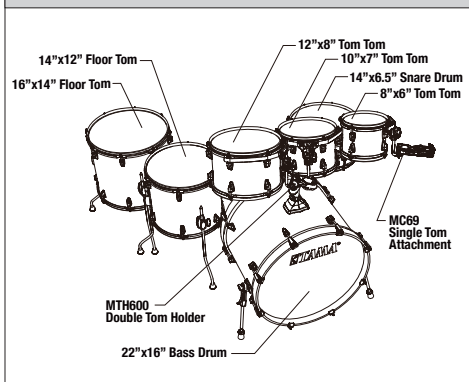

# INDIVIDUAL MODEL NUMBERS

Diameter	Depth	Model No.	
<b>Bass Drums</b>			
18" (w/ bass drum lifter)	14"	CLB18RL	2.383,00
20"	16"	CLB20D	2.556,00
22"	16"	CLB22D	2.730,00
24"	16"	CLB24D	2.947,00
<b>Floor Toms</b>			
14"	12"	CLF14A	1.341,00
14"	14"	CLF14D	1.341,00
16"	14"	CLF16A	1.515,00
18"	16"	CLF18D	1.688,00
<b>Tom Toms</b>			
8"	6"	CLT8H	864,00
10"	7"	CLT10R	950,00
12"	8"	CLT12R	1.081,00
13"	9"	CLT13R	1.211,00
<b>Snare Drums</b>			
14"	5"	CLS145	864,00
14"	6.5"	CLS1465	907,00

## SPECIFICATIONS

### Shells

TT/FT/SD: 5mm 4ply Maple + 2 outer ply Lacebark Pine  
 BD: 7mm 6ply Maple + 2 outer ply Lacebark Pine

Star-Mount System

Low-Mass Lugs

Power Craft II Drum Heads

## FINISHES (Lacquer)



Caribbean Lacebark Pine Fade  
PCLP



Gloss Garnet Lacebark Pine  
PGGP



Gloss Sapphire Lacebark Pine  
PGHP



Gloss Java Lacebark Pine  
PGJP

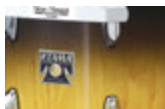

Gloss Lacebark Pine Fade  
PGLP

# SUPERSTAR CLASSIC

Lacquer Finishes



**COLOR** Gloss Natural Blonde **GNL**

## CL52KRS 5pc basic kit

including:  
 22"x16" bass drum  
 10"x7" tom tom  
 12"x8" tom tom  
 16"x14" floor tom  
 14"x6.5" snare drum  
 MTH600 double tom holder

## KIT CONFIGURATIONS LIST

### [22" BD 3pc Shell Kit]

<b>CL32RZS</b>	3.468,00
<b>CL32RZ</b> w/SM5W hardware pack	4.639,00

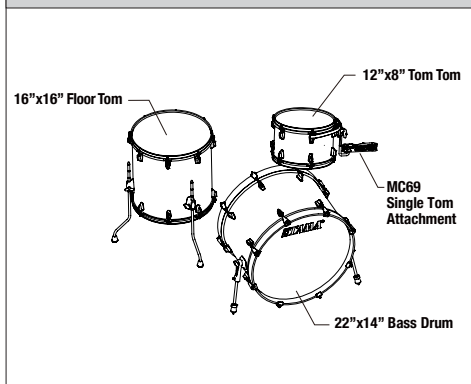

### [20" BD 5pc Shell Kit]

<b>CL50RS</b>	4.553,00
<b>CL50R</b> w/SM5W hardware pack	5.724,00

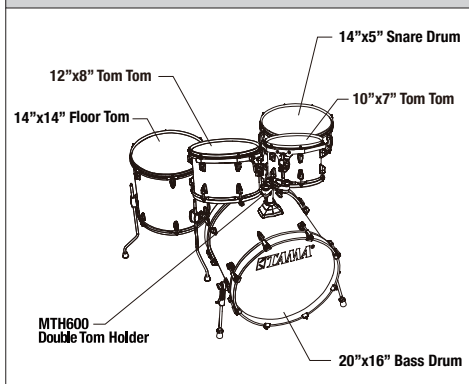

### [22" BD 5pc Shell Kit]

<b>CL52KRS</b>	4.553,00
<b>CL52KR</b> w/SM5W hardware pack	5.724,00

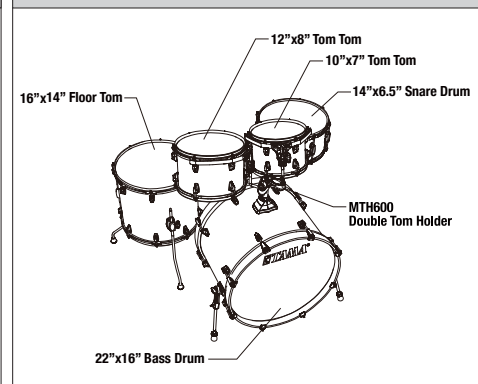



# INDIVIDUAL MODEL NUMBERS

Diameter	Depth	Model No.	
<b>Bass Drums</b>			
18"(w/ bass drum lifter)	14"	CLB18RL	2.383,00
20"	16"	CLB20D	2.556,00
22"	14"	CLB22RZ	2.730,00
22"	16"	CLB22D	2.730,00
24"	16"	CLB24D	2.947,00
<b>Floor Toms</b>			
14"	12"	CLF14A	1.341,00
14"	14"	CLF14D	1.341,00
16"	14"	CLF16A	1.515,00
16"	16"	CLF16D	1.515,00
18"	16"	CLF18D	1.688,00
<b>Tom Toms</b>			
8"	6"	CLT8H	864,00
10"	7"	CLT10R	950,00
12"	8"	CLT12R	1.081,00
13"	9"	CLT13R	1.211,00
<b>Snare Drums</b>			
14"	5"	CLS145	864,00
14"	6.5"	CLS1465	907,00

## SPECIFICATIONS

### Shells

TT/FT/SD: 5mm 4ply Maple + 2 outer ply Lacebark Pine  
 BD: 7mm 6ply Maple + 2 outer ply Lacebark Pine

Star-Mount System

Low-Mass Lugs

Power Craft II Drum Heads

## FINISHES (Lacquer)



Gloss Natural Blonde  
GNL



Blue Lacquer Burst  
BAB



Coffee Fade  
CFF



Tangerine Lacquer Burst  
TLB



Transparent Black Burst  
TPB

# SUPERSTAR CLASSIC

Unicolor Wrap Finishes



**COLOR** Ice Ash Wrap **ICA**

## CK52KRS 5pc basic kit

including:  
 22"x16" bass drum  
 10"x7" tom tom  
 12"x8" tom tom  
 16"x14" floor tom  
 14"x6.5" snare drum  
 MTH600 double tom holder

## KIT CONFIGURATIONS LIST

### [22" BD 3pc Shell Kit]

<b>CK32RZS</b>	3.120,00
CK32RZ w/SM5W hardware pack	4.292,00

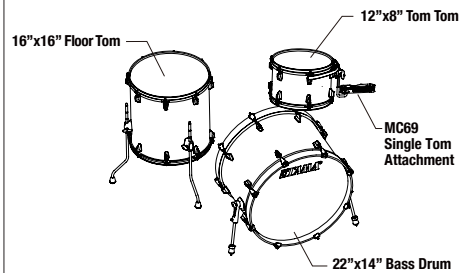

### [20" BD 5pc Shell Kit]

<b>CK50RS</b>	4.205,00
CK50R w/ SM5W hardware pack	5.377,00

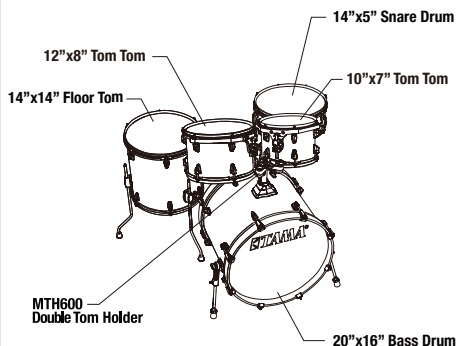

### [22" BD 5pc Shell Kit]

<b>CK52KRS</b>	4.205,00
CK52KR w/SM5W hardware pack	5.377,00

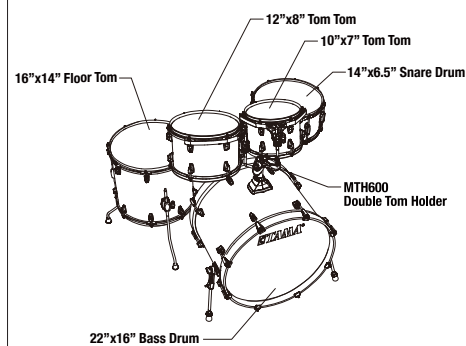

# INDIVIDUAL MODEL NUMBERS

Diameter	Depth	Model No.	
<b>Bass Drums</b>			
18" (w/ bass drum lifter)	14"	CKB18RL	2.209,00
20"	16"	CKB20D	2.383,00
22"	14"	CKB22RZ	2.513,00
22"	16"	CKB22D	2.513,00
24"	16"	CKB24D	2.686,00
<b>Floor Toms</b>			
14"	12"	CKF14A	1.254,00
14"	14"	CKF14D	1.254,00
16"	14"	CKF16A	1.428,00
16"	16"	CKF16D	1.428,00
18"	16"	CKF18D	1.515,00
<b>Tom Toms</b>			
8"	6"	CKT8H	777,00
10"	7"	CKT10R	864,00
12"	8"	CKT12R	907,00
13"	9"	CKT13R	994,00
<b>Snare Drums</b>			
14"	5"	CKS145	777,00
14"	6.5"	CKS1465	820,00

## SPECIFICATIONS

### Shells

TT/FT/SD: 5mm 4ply Maple + 2 outer ply Lacebark Pine  
 BD: 7mm 6ply Maple + 2 outer ply Lacebark Pine

Star-Mount System

Low-Mass Lugs

Power Craft II Drum Heads

## FINISHES (Unicolor Wrap)



Ice Ash Wrap  
ICA



Natural Ebony Tiger Wrap  
NET



Indigo Sparkle  
ISP



Midnight Gold Sparkle  
MGD



# IMPERIALSTAR

Unicolor Wrap Finish w/Black Nickel Shell Hardware



**COLOR** Blacked Out Black **BOB**

## IP52H6WBN 22" Bass Drum 5pc basic kit

**Drums:**  
22"x18" bass drum, 10"x7" & 12"x8" tom toms, 16"x14" floor tom, 14"x5" snare drum.

**Hardware:**  
double tom holder, hi-hat stand, drum pedal, snare stand, boom cymbal stand, straight cymbal stand, drum throne.

### [Meinl HCS Brass Cymbals]

All the kits come with Meinl HCS Brass 14" Hi-hat, 16" Crash & 20" Ride cymbals

## KIT CONFIGURATIONS LIST

[20" BD 5pc Kit w/ Hardware & MEINL Cymbals]

**NEW**

IP50H6WBN

4.770,00

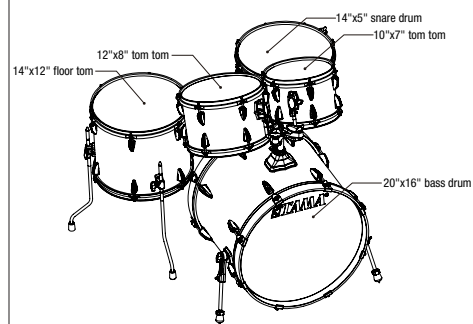

[22" BD 5pc Kit w/ Hardware & MEINL Cymbals]

IP52H6WBN

4.770,00

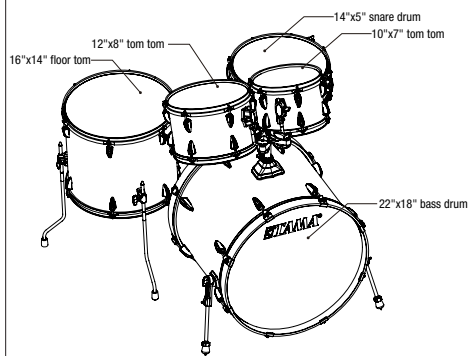

# INDIVIDUAL MODEL NUMBERS

Diameter	Depth	Model No.	
<b>Bass Drums</b>			
18"	14"	IPB18RWB	1.415,00
20"	16"	IPB20DWB	1.523,00
22"	18"	IPB22EWB	1.575,00
<b>Floor Toms</b>			
14"	12"	IPF14AB	712,00
16"	14"	IPF16AB	786,00
18"	16"	IPF18DB	890,00
<b>Tom Toms</b>			
8"	7"	IPT8AB	469,00
10"	7"	IPT10RB	503,00
12"	8"	IPT12RB	521,00
13"	9"	IPT13RB	551,00
<b>Snare Drums</b>			
14"	5"	IPS145B	612,00
14"	6.5"	IPS1465B	634,00

## SPECIFICATIONS

### Shells

All Poplar Shell: 8mm 6ply

Omnisphere Tom Holder  
Wood Bass Drum Hoops  
Double Braced Hardware

## FINISH (Unicolor Wrap)



Blacked Out Black  
**BOB**

# IMPERIALSTAR

## Unicolor Wrap Finishes w/Chrome Shell Hardware

In 2006, the Imperialstar line made its successful comeback, providing everything a drummer needs at an affordable price. Now, Imperialstar is refined to feature matching bass drum hoops, Stage Master double-braced hardware, and Iron Cobra 200 bass drum pedal.



**COLOR** Electric Yellow **ELY**

### IP52H6W 22" Bass Drum 5pc basic kit

**Drums:**  
22"x18" bass drum, 10"x7" & 12"x8" tom toms, 16"x14" floor tom, 14"x5" snare drum.

**Hardware:**  
double tom holder, hi-hat stand, drum pedal, snare stand, boom cymbal stand, straight cymbal stand, drum throne.

### [Meinl HCS Brass Cymbals]

All the kits come with Meinl HCS Brass 14" Hi-hat, 16" Crash & 20" Ride cymbals

## KIT CONFIGURATIONS LIST

### [18" BD 5pc Kit w/ Hardware & MEINL Cymbals]

**IP58H6W** 4.119,00

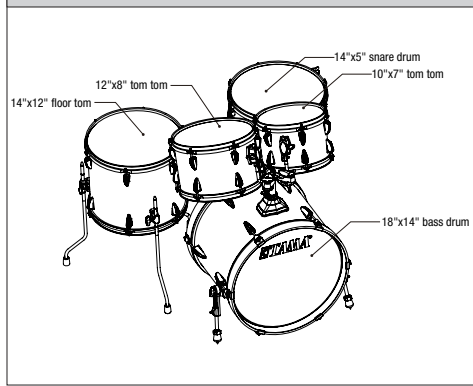

### [20" BD 5pc Kit w/ Hardware & MEINL Cymbals]

**IP50H6W** 4.336,00

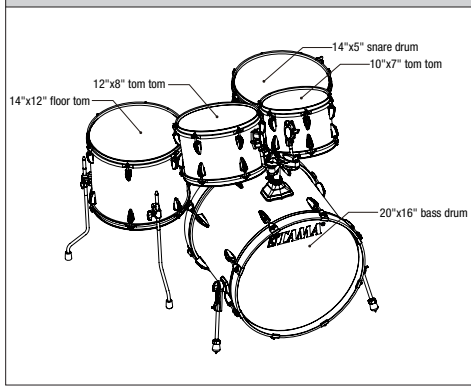

### [22" BD 5pc Kit w/ Hardware & MEINL Cymbals]

**IP52H6W** 4.336,00

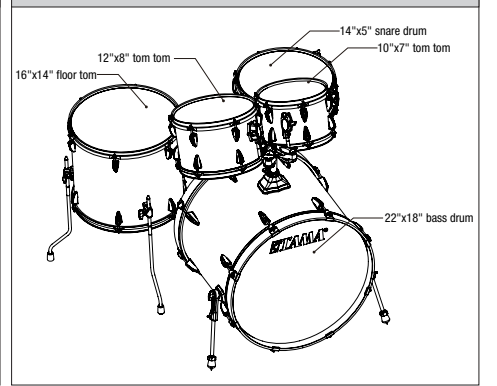

### [22" BD 6pc Kit w/ Hardware & MEINL Cymbals]

**IP62H6W** 4.770,00

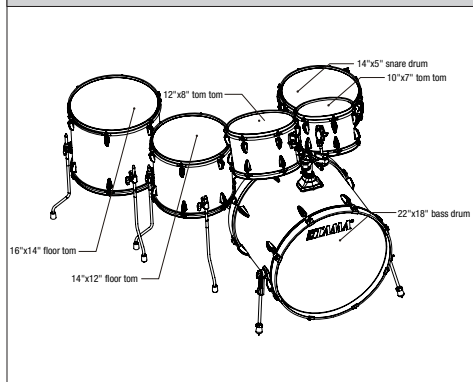



# INDIVIDUAL MODEL NUMBERS

Diameter	Depth	Model No.	
<b>Bass Drums</b>			
18"	14"	IPB18RW	1.415,00
20"	16"	IPB20DW	1.523,00
22"	18"	IPB22EW	1.575,00
<b>Floor Toms</b>			
14"	12"	IPF14A	712,00
16"	14"	IPF16A	786,00
18"	16"	IPF18D	890,00
<b>Tom Toms</b>			
8"	7"	IPT8A	469,00
10"	7"	IPT10R	503,00
12"	8"	IPT12R	521,00
13"	9"	IPT13R	551,00
<b>Snare Drums</b>			
14"	5"	IPS145	612,00
14"	6.5"	IPS1465	634,00

## SPECIFICATIONS

### Shells

All Poplar Shell: 8mm 6ply

Omnisphere Tom Holder  
Wood Bass Drum Hoops  
Double Braced Hardware

## FINISHES (Unicolor Wrap)



Coffee Teak Wrap  
**CTW**



Burnt Red Mist  
**BRM**



Electric Yellow  
**ELY**



Hairline Black  
**HBK**



Hairline Blue  
**HLB**

# STAGESTAR NEW

## Unicolor Wrap Finishes

With 50 years of experience, TAMA knows what drummers really want. Which is why TAMA has the set you need, want and can afford no matter how long you've been playing drums or what budget you have to work with. Now TAMA has launched the affordable kit to ever incorporate many nice features – STAGESTAR. The new STAGESTAR kit comes with Omni-ball tom holder as well as double braced hardware for increased stability.



**COLOR** Candy Red Sparkle **CDS**

### ST52H5 22" Bass Drum 5pc basic kit

**Drums:**  
22" x 16" bass Drum, 10" x 8" tom tom, 12" x 9" tom tom, 16" x 15" floor tom, 14" x 5.5" snare drum.

**Hardware:**  
double tom holder, hi-hat stand, drum pedal, snare stand, boom cymbal stand, drum throne.

### [Meinl BCS Brass Cymbals]

All the kits come with Meinl BCS Brass 14" Hi-hat & 18" Crash-Ride cymbals

## KIT CONFIGURATIONS LIST

[20" BD 5pc Kit w/ Hardware & MEINL Cymbals]

**ST50H5** 2.947,00

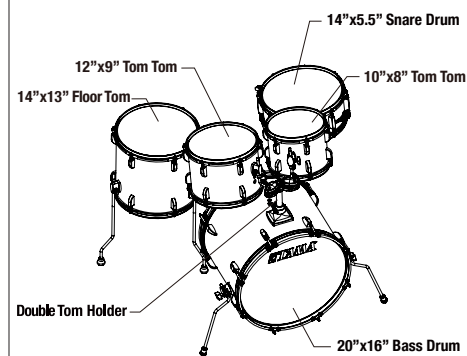

[22" BD 5pc Kit w/ Hardware & MEINL Cymbals]

**ST52H5** 2.947,00

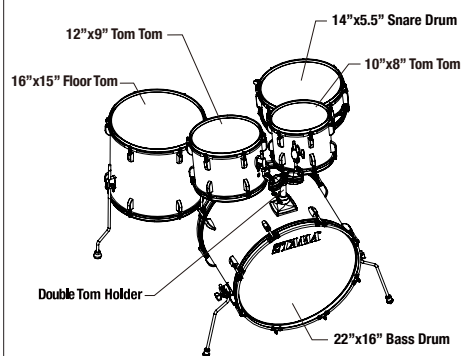

## FINISHES (Unicolor Wrap)



Candy Red Sparkle  
**CDS**



Sea Blue Mist  
**SEM**



Black Night Sparkle  
**BNS**

# CLUB-JAM

## Lacquer Finish

The "Club-JAM" Kit adopts some ideas from vintage kits, such as a cymbal holder mounted directly on the bass drum shell and curved bass drum spurs, further setting it apart from the typical compact kit. Focused yet deep sound from Poplar shell is just right for small and intimate gigs. Its compact size and configuration make it ideal for working drummers, and it fits comfortably on just about any stage.



**COLOR** Satin Blonde **SBO**

### LJL48S 18" Bass Drum 4pc basic kit

**Drums:**  
18"x12" bass drum, 10"x7" tom tom, 14"x7" floor tom, 13"x5" snare drum.

**Hardware:**  
single tom holder, cymbal holder.

## KIT CONFIGURATION LIST

[18" BD 4pc Shell Kit]

LJL48S 2.730,00

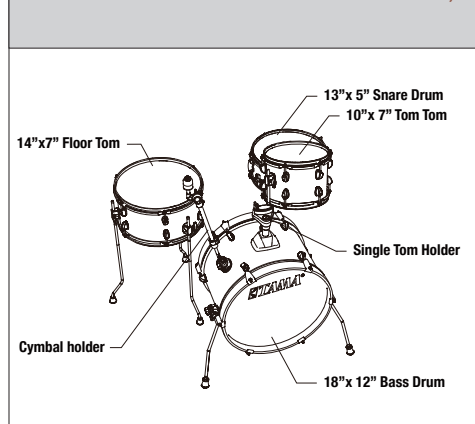

## FINISH (Lacquer)



Satin Blonde  
**SBO**



# CLUB-JAM

Unicolor Wrap Finishes



**COLOR** Candy Apple Mist **CPM**

## LJK48S 18" Bass Drum 4pc basic kit

**Drums:**  
18"x12" bass drum, 10"x7" tom tom, 14"x7" floor tom, 13"x5" snare drum.

**Hardware:**  
single tom holder, cymbal holder.

## KIT CONFIGURATION LIST

[18" BD 4pc Shell Kit]

LJK48S 2.252,00

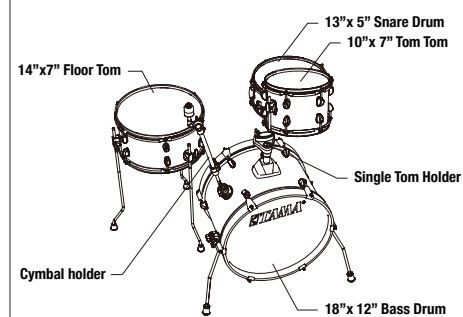

## FINISHES (Unicolor Wrap)

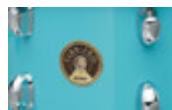

Aqua Blue  
AQB



Charcoal Mist  
CCM



Candy Apple Mist  
CPM



Cream Marble Wrap  
CMW

# CLUB-JAM MINI

## Unicolor Wrap Finishes

The simple and sweet TAMA Club-JAM Mini kit is just a kick and snare. Its clear yet deep sound from the Poplar shell is just right for those small and intimate gigs. While its compact size and configuration fit comfortably at any small venue or street show. The Drum Bag Set for this kit (DSS28LJ) allows for smooth transportation (sold separately). If one needs to configure it as a regular drum kit, also available are add-on drums including the 10"x7" tom tom with attachment and a 14"x7" floor tom.



**COLOR** Candy Apple Mist **CPM**

### LJK28S 18" Bass Drum 2pc basic kit

**Drums:**  
18"x7" bass drum, 12"x5" snare drum.

### LJKT10F14 Add-on pack

Add-on tom and floor tom package is sold separately.  
10"x7" tom tom, 14"x7" floor tom, single tom attachment

**950,00**

## KIT CONFIGURATION LIST

[18" BD 2pc Shell Kit]

LJK28S 1.471,00

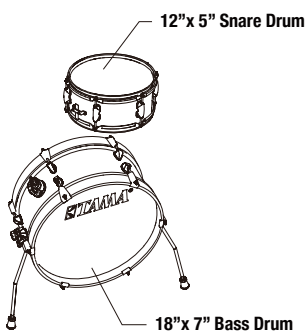

## FINISHES (Unicolor Wrap)

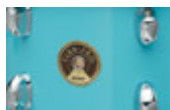

Aqua Blue  
AQB



Charcoal Mist  
CCM



Candy Apple Mist  
CPM

# CLUB-JAM FLYER

## Unicolor Wrap Finishes

The Club-JAM Flyer is the ultimate compact-sized drum kit. It features a 14"x10" bass drum with bass drum lifter, 8"x6" tom tom, 10"x9" floor tom and a 10"x5" snare drum. The Club-JAM Flyer kit delivers a very-well balanced authentic drum sound despite its smaller-sized shells. The Club-JAM Flyer kit's compact size and configuration make it perfect for any small venue or street show. A special drum bag set for the Club-JAM Flyer kit allows for easy transportation (DSS44LJ / sold separately).



**COLOR** Aqua Blue **AQB**

### LJK44H4 14" Bass Drum 4pc basic kit w/ hardware

**Drums:**

14"x10" bass drum w/ bass drum lifter, 8"x6" tom tom, 10"x9" floor tom, 10"x5" snare drum.

**Hardware:**

single tom holder, hi-hat stand, drum pedal, snare stand, drum throne.

## KIT CONFIGURATION LIST

[14" BD 4pc Shell Kit]

LJK44S 2.166,00

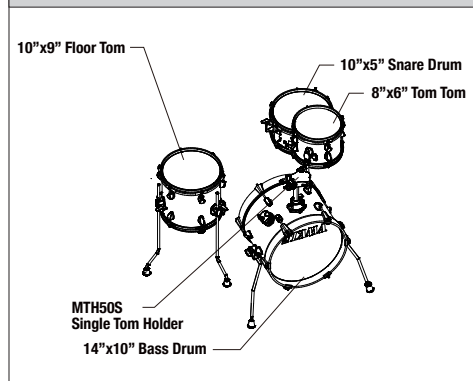

## FINISHES (Unicolor Wrap)



Aqua Blue  
AQB



Candy Apple Mist  
CPM

# CLUB-JAM PANCAKE

## Unicolor Wrap Finishes

The Club-JAM Pancake kit combines the benefits of a compact & easily portable drum kit with professional quality sound and durability. This is achieved through the lightweight and minimalist design of the Club-JAM series. As the lightest and smallest option in the Club-JAM series, this Club-JAM Pancake kit offers a professional quality sound in any situation. The 3.5" deep tom and floor tom, paired with a 4" deep snare drum and bass drum can be easily packed in just a single bag thanks to the ultrashallow shell. The single-headed toms produce a crisp and warm sound with a strong attack. The double-headed snare drum produces a bright and sharp sound, along with significant low-end from the double-headed bass drum. For every genre, whether you're playing live or in the studio, the Club-JAM Pancake kit delivers a new, unique, and satisfying musical experience.



**COLOR** Burnt Red Mist **BRM**

### LJK48P 18" Bass Drum 4pc basic kit

**Drums:**  
18"x4" bass drum, 10"x3.5" tom tom, 13"x3.5" floor tom, 12"x4" snare drum.

**Hardware:**  
single tom attachment

### LJKB18H3 Bass Drum

**Drums:**  
18"x4" bass drum

**777,00**

## KIT CONFIGURATION LIST

[18" BD 4pc Shell Kit]

LJK48P 1.818,00

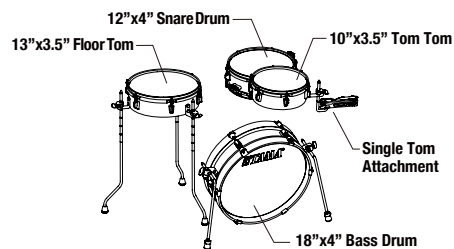

## FINISHES (Unicolor Wrap)



Healine Black  
**HBK**



Burnt Red Mist  
**BRM**



# COCKTAIL-JAM

## Unicolor Wrap Finishes

The Cocktail-JAM Kit™ is a TAMA original in both appearance and sound. It's ideal for hip-hop, jazz, intimate acoustic settings, and tight rehearsal rooms. Completely compact, this kit can easily be set up and played using a throne in spaces much smaller than a typical drum set. Additionally, the Cocktail-JAM Kit and its hardware can be easily packed into just two bags (included with the kit), making it super portable and easy to transport to any gig. Have fun jamming with the Cocktail-JAM Kit!



**COLOR** Bright Orange Sparkle **BOS**

### CJB46C basic kit w/ cymbal attachments

**Drums:**  
16"x6" bass drum, 10"x5" tom tom, 14"x5.5" floor tom, 12"x5" snare drum, Sound Focus Pad, drum bag, hardware bag.

**Hardware:**  
single tom attachments (x2), single pedal, cymbal attachment, hi-hat attachment.

## KIT CONFIGURATION LIST

[16" BD 4pc Kit]

CJB46C w/ MCAX5366 Clamp kit 3.902,00

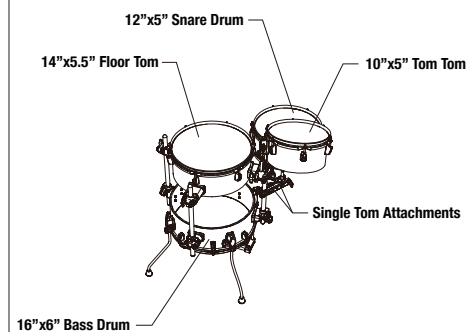

## FINISHES (Unicolor Wrap)



Bright Orange Sparkle  
**BOS**



Indigo Sparkle  
**ISP**

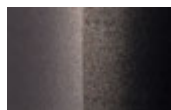

Midnight Gold Sparkle  
**MGD**

# TRUE TOUCH TRAINING KIT

True Touch Training Kit is a revolutionary practice kit that not only offers the low volume required for practicing at home, but also allows drummers to perform critical technique refinement needed to improve their musical expression. The combination of quiet acoustic volume, realistic acoustic touch and sensitive dynamic expression results in a highly satisfying acoustic drum feeling, something that has not been possible with conventional practice kits until now.



## TTK5S Complete Kit

including:  
 Solid Kick Bass Pad  
 AAD Snare Pad  
 8" high tom pad w/ mounting clamp  
 8.5" low tom pad w/ mounting clamp  
 9" floor tom w/ clamp & boom arm & L-rod  
 Tom stand

\*Hi-hat stand, cymbal stand, kick pedal and cymbals are not included.

## KIT CONFIGURATIONS LIST

[TTK5S 5pc Kit]



\*Hi-hat stand, cymbal stand, kick pedal and cymbals are not included.

including:  
 Solid Kick Bass Pad  
 AAD Snare Pad  
 8" high tom pad w/ mounting clamp  
 8.5" low tom pad w/ mounting clamp  
 9" floor tom w/ clamp & boom arm & L-rod  
 Tom stand

**2.600,00**

[TTK4S 4pc Kit]



\*Hi-hat stand, cymbal stand, kick pedal and cymbals are not included.

including:  
 Solid Kick Bass Pad  
 AAD Snare Pad  
 8" high tom pad w/ mounting clamp  
 9" floor tom w/ clamp & boom arm & L-rod  
 Tom stand

**2.166,00**

[TTK2S 2pc Kit]



\*Hi-hat stand, cymbal stand, kick pedal and cymbals are not included.

including:  
 Solid Kick Bass Pad  
 AAD Snare Pad

**1.298,00**

## ADD-ON ITEMS

AAD Snare Pad



TTSD10

**647,00**

Acousti-Tone Tom Pad



THT8 8" tom tom

**473,00**

TTLT85 8.5" tom tom  
 \*Mounting clamp is included.

**516,00**

Acousti-Tone Floor Tom Pad



TFT9 9" floor tom

\*Mounting Clamp, boom arm & L-Rod are included.

**560,00**

Solid Kick Bass Pad



TTBD6

**733,00**

Tom Stand



TTKTS

**239,00**

# SNARE DRUMS

TAMA has a wide variety of snare drum options to complement our array of drum kits. From our super high end STAR snare drums to the METALWORKS series, which offers quality at a great price, there is a model to fit every drummer's desired sound and budget.

## STAR BUBINGA



Color: Natural Indian Laurel -LNTI

### TBS1465S

MADE IN JAPAN

Please refer to the STAR Bubinga drum kit page to see available sizes, finishes, and inlay options.

Lug: MSL90SC  
Hoop: Die-Cast Hoop (8 hole)  
Strainer/Butt: MLS50A/MLS50B  
Snare Wire: 14"=MS20RL14C,  
13"=MS20RL13C

**4.683,00**

## STAR MAPLE



Color: Gloss Natural Curly Maple -RGCM

### TMS1465S

MADE IN JAPAN

Please refer to the STAR Maple drum kit page to see available sizes, finishes, and inlay options.

Lug: MSL90SC  
Hoop: Die-Cast Hoop (8 hole)  
Strainer/Butt: MLS50A/MLS50B  
Snare Wire: 14"=MS20RL14C,  
13"=MS20RL13C

**4.683,00**

## STAR WALNUT



Color: Garnet Japanese Sen Burst - AGJB

### TWS1465

MADE IN JAPAN

Please refer to the STAR Walnut drum kit page to see available sizes and finishes.

Lug: MSL90SC  
Hoop: Die-Cast Hoop (8 hole)  
Strainer/Butt: MLS50A/MLS50B  
Snare Wire: 14"=MS20RL14C,  
13"=MS20RL13C

**3.294,00**

## STAR SOLID MAPLE



Color: Oiled Natural Maple -OMP

### TLM146S

MADE IN JAPAN

Shell: 8mm Solid Maple, w/ 8mm Sound Focus Rings

Size: 14"x6"  
Lug: MSL90SC  
Hoop: Die-Cast Hoop (8 hole)  
Strainer/Butt: MLS50A/MLS50B  
Snare Wire: MS20RL14C  
Color: Oiled Natural Maple (OMP)  
[Inlay Option] Outside Inlay, or w/o Inlay

**5.160,00**

## STAR SOLID MAHOGANY



Color: Oiled Natural Mahogany -OMH

### TLH146S

MADE IN JAPAN

Shell: 7mm Solid Mahogany w/ 7mm Sound Focus Rings  
Size: 14"x6"  
Lug: MSL90SC  
Hoop: Die-Cast Hoop (8 hole)  
Strainer/Butt: MLS50A/MLS50B  
Snare Wire: MS20RL14C  
Color: Oiled Natural Mahogany (OMH)  
[Inlay Option] Outside Inlay, or w/o Inlay

**5.160,00**

## STAR STAVE WALNUT



Color: Oiled Natural Walnut -OWN

### TWV146S

MADE IN JAPAN

Shell: 10mm, 16pcs Stave Walnut  
Size: 14"x6"  
Lug: MSL90SC  
Hoop: Die-Cast Hoop (8 hole)  
Strainer/Butt: MLS50A/MLS50B  
Snare Wire: MS20RL14C  
Color: Oiled Natural Walnut (OWN)  
[Inlay Option] Outside Inlay, or w/o Inlay

**4.683,00**

## STAR RESERVE SOLID MAPLE



Color: Oiled Natural Maple -OMP

### TLM145S

MADE IN JAPAN

Shell: 8mm Solid Maple w/ 8mm Solid Maple Sound Focus Rings  
Size: 14"x5"  
Lug: MTL150  
Hoop: 2.3mm Brass Sound Arc Hoop (8 hole)  
Strainer/Butt: MLS50A / MLS50B  
Snare Wire: MS20L14C8  
Color: Oiled Natural Maple (OMP)

**5.638,00**

## STAR RESERVE BUBINGA/MAPLE



Color: Caramel Olive Ash Burst -OCOB

### TMBS158S

MADE IN JAPAN

Shell: 5.5mm, 8ply Bubinga/Maple (1inner ply Cordia+2ply Bubinga+4ply Maple+1outer ply Olive Ash)  
Size: 15"x8"  
Lug: MSL90TC  
Hoop: Brass Mighty Hoop (8 hole)  
Strainer/Butt: MLS50A / MLS50B  
Snare Wire: MS20SN15S  
Color: Caramel Olive Ash Burst (OCOB)

**4.683,00**

## STAR RESERVE WALNUT/BUBINGA



Color: Gloss Claro Walnut -GCW

### TBWS1465S

MADE IN JAPAN

Shell: 5.5mm, 4ply Walnut + 2ply Bubinga + 1 outer ply Claro Walnut w/Maple Sound Focus Rings  
Size: 14"x6.5"  
Lug: MTL160  
Hoop: Sound Arc Hoop (10 Hole)  
Strainer/Butt: MLS50A / MLS50B  
Snare Wire: MS20RL14C  
Color: Gloss Claro Walnut (GCW)

**4.683,00**

## STAR RESERVE HAMMERED COPPER



### TC1465H

MADE IN JAPAN

Shell: 1.5mm Hammered Copper  
Size: 14"x6.5"  
Lug: MSL90SC  
Hoop: Customized Brass Mighty Hoop (8 Hole)  
Strainer/Butt: MLS50A / MLS50B  
Snare Wire: MS20RL14C

**4.683,00**

## STAR RESERVE STAVE JATOBA



Color: Oiled Natural Jatoba -OJT

### TVJ147S

MADE IN JAPAN

Shell: 10mm, 16pcs Stave Jatoba  
Size: 14"x7"  
Lug: MTL160  
Hoop: Die-Cast Hoop (8 Hole)  
Strainer/Butt: MLS50A / MLS50B  
Snare Wire: MS20RL14C  
Color: Oiled Natural Jatoba (OJT)

5.160,00

## STAR RESERVE HAMMERED BRASS



### TBRS1455H

MADE IN JAPAN

Shell: 1.5mm Hand Hammered Brass  
Size: 14"x5.5"  
Lug: MSL90SC  
Hoop: Customized Brass Mighty Hoop (8 hole)  
Strainer/Butt: MLS50A / MLS50B  
Snare Wire: MS20RL14C

4.683,00

## STAR RESERVE HAMMERED ALUMINUM



### TAS1465H

MADE IN JAPAN

Shell: 3mm Hand Hammered Aluminum  
Size: 14"x6.5"  
Lug: MSL90SC  
Hoop: Brass Sound Arc Hoop (8 hole)  
Strainer/Butt: MLS50A / MLS50B  
Snare Wire: MS20RL14C

4.683,00

## STAR RESERVE STAVE ASH



Color: Oiled Amber Ash -OAA

### TVA1465S

MADE IN JAPAN

Shell: 10mm/20pcs Stave Ash Shell  
Size: 14"x6.5"  
Lug: MSL90SC  
Hoop: Sound Arc Hoop (10 hole)  
Strainer/Butt: MLS50A/MLS50B  
Snare Wire: MS20RL14C  
Color: Oiled Amber Ash (OAA)

4.770,00

## STAR RESERVE SOLID JAPANESE CEDAR



Color: Burnt Oiled Cedar -BOC

### TLJC146

MADE IN JAPAN

Shell: 8mm Solid Japanese Cedar  
Size: 14"x6"  
Lug: MSL90SC  
Hoop: Customized Brass Mighty Hoop (8 hole)  
Strainer/Butt: MLS50A/MLS50B  
Snare Wire: MS20SN14B  
Color: Burnt Oiled Cedar (BOC)

5.638,00

## MASTERCRAFT BELL BRASS



### BB-156

MADE IN JAPAN

Shell: 3mm Cast Bell Brass  
Size: 14"x6.5"  
Lug: Original Superstar Lug (6371N)  
Hoop: Die-Cast Hoop (10 hole)  
Strainer/Butt: Roller Action (6302N/6303N/6338N)  
Snare Wire: 20-strand Carbon Steel Long Snare Wires (6035N)  
Inside Muffler: One-Touch Tone Control (6552N)

17.356,00

## STARPHONIC MAPLE



Color: Satin Mappa Burl - STM

### PMM146

MADE IN JAPAN

Shell: 6mm, 6ply Maple + 1 Mappa Burl outer ply  
Size: 14"x6"  
Lug: Freedom Lug  
Hoop: Grooved Hoop  
Strainer/Butt: MLS50A/MLS50B  
Snare Wire: MS20RL14C  
Color: Satin Mappa Burl (STM)

2.600,00

## STARPHONIC BUBINGA



Color: Matte Natural Cordia -MNC

### PBC146

MADE IN JAPAN

Shell: 7mm, 8ply Bubinga + 1 Cordia outer ply  
Size: 14"x6"  
Lug: Freedom Lug  
Hoop: Grooved Hoop  
Strainer/Butt: MLS50A/MLS50B  
Snare Wire: MS20RL14C  
Color: Matte Natural Cordia (MNC)

2.600,00

## STARPHONIC WALNUT



Color: Gloss Black Walnut Burl -GWB

### PWB147

MADE IN JAPAN

Shell: 6mm, 6ply American Black Walnut Shell + 1 outer ply Black Walnut Burl  
Size: 14"x7"  
Lug: Freedom Lug  
Hoop: Grooved Hoop  
Strainer/Butt: MLS50A/MLS50B  
Snare Wire: MS20RL14C  
Color: Gloss Black Walnut Burl (GWB)

2.817,00

## STARPHONIC BRASS



### PBR146

MADE IN JAPAN

Shell: 1.2mm Brass  
Size: 14"x6"  
Lug: Freedom Lug  
Hoop: Grooved Hoop  
Strainer/Butt: MLS50A/MLS50B  
Snare Wire: MS20RL14C

2.339,00

## STARPHONIC BELL BRASS



### PBB146

MADE IN JAPAN

Shell: 3mm Bell Brass  
Size: 14"x6"  
Lug: Freedom Lug  
Hoop: Grooved Hoop  
Strainer/Butt: MLS50A/MLS50B  
Snare Wire: MS20RL14C

10.325,00

## STARPHONIC COPPER



### PCP147

MADE IN JAPAN

Shell: 1.2mm Copper  
Size: 14"x7"  
Lug: Freedom Lug  
Hoop: Grooved Hoop  
Strainer/Butt: MLS50A/MLS50B  
Snare Wire: MS20RL14C

3.034,00



## STARPHONIC ALUMINUM



### PAL146

MADE IN JAPAN

Shell: 1.2mm Seamless Aluminum  
Size: 14"x6"  
Lug: Freedom Lug  
Hoop: Grooved Hoop  
Strainer/Butt: MLS50A/MLS50B  
Snare Wire: MS20RL14C

**2.166,00**

## STARPHONIC STAINLESS STEEL



### PSS146

MADE IN JAPAN

Shell: 1mm Stainless Steel w/ R.S.E.  
Size: 14"x6"  
Lug: Freedom Lug  
Hoop: Grooved Hoop  
Strainer/Butt: MLS50A/MLS50B  
Snare Wire: MS20RL14C

**3.251,00**

## STARPHONIC STEEL



### PST146

MADE IN JAPAN

Shell: 1mm Steel  
Size: 14"x6"  
Lug: Freedom Lug  
Hoop: Grooved Hoop  
Strainer/Butt: MLS50A/MLS50B  
Snare Wire: MS20RL14C

**1.862,00**

## STARCLASSIC MAPLE EXOTIC FINISH



### MES1465U

Please refer to the Starclassic Maple Exotic Finish drum kit page to see available sizes and finishes.

Lug: MSL-SCT  
Hoop: Die-Cast Hoop  
Strainer/Butt: MLS50A/MLS50B  
Snare Wire: 14"=MS20RL14C,  
13"=MS20RL13C

**2.773,00**

Color: Tobacco Sunburst Movingui -VTBV

## STARCLASSIC MAPLE LACQUER FINISH



Color: Antique Maple -ATM

### MAS1455

Please refer to the Starclassic Maple Lacquer Finish drum kit page to see available sizes and finishes. Antique Maple (ATM) is also available.

Lug: MSL-SCT  
Hoop: Die-Cast Hoop  
Strainer/Butt: MLS50A/MLS50B  
Snare Wire: 14"=MS20RL14C,  
13"=MS20RL13C

**2.686,00**

## STARCLASSIC MAPLE DURACOVER WRAP FINISH



Color: Blue and White Oyster -BWO

### MRS136

Please refer to the Starclassic Maple Duracover Wrap Finish drum kit page to see available sizes and finishes.

Lug: MSL-SCT  
Hoop: Die-Cast Hoop  
Strainer/Butt: MLS50A/MLS50B  
Snare Wire: 14"=MS20RL14C,  
13"=MS20RL13C

**2.469,00**

## STARCLASSIC WALNUT/BIRCH LACQUER FINISH



Color: Molten Brown Burst -MBR

### WBSS65

Please refer to the Starclassic Walnut/Birch Lacquer Finish drum kit page to see available sizes and finishes.

Lug: MSL-SCT  
Hoop: Die-Cast Hoop  
Strainer/Butt: MLS30A/MLS30B  
Snare Wire: 14"=MS20RL14C,  
13"=MS20RL13C

**2.035,00**

## STARCLASSIC WALNUT/BIRCH DURACOVER WRAP FINISH



Color: Charcoal Onyx -CCO

### WBR65

Please refer to the Starclassic Walnut/Birch Duracover Wrap Finish drum kit page to see available sizes and finishes.

Lug: MSL-SCT  
Hoop: Die-Cast Hoop  
Strainer/Butt: MLS30A/MLS30B  
Snare Wire: 14"=MS20RL14C,  
13"=MS20RL13C

**2.035,00**

## STARCLASSIC PERFORMER LACQUER FINISH



Color: Sky Blue Aurora -SKA

### MBSS65

Please refer to the Starclassic Performer Lacquer Finish drum kit page to see available sizes and finishes.

Lug: MSL-SCT  
Hoop: Die-Cast Hoop  
Strainer/Butt: MLS30A/MLS30B  
Snare Wire: 14"=MS20RL14C,  
13"=MS20RL13C

**1.471,00**

## S.L.P. G-BUBINGA



Color: Natural Quilted Bubinga -NOB

### LGB146

NEW

Shell: 10mm, 11ply Bubinga + 1 outer ply Quilted Bubinga  
Size: 14"x6"  
Lug: MSL-SCTBN  
Hoop: Steel Mighty Hoop (10 Hole)  
Strainer/Butt: MLS50ABN / MLS50BBN  
Snare Wire: MS20SN14S  
Color: Natural Quilted Bubinga (NOB)

**2.252,00**

## S.L.P. G-MAPLE



Color: Kona Mappa Burl -KMB

### LGM146

Shell: 11mm, 12ply Maple + 1 outer ply Mappa Burl  
Size: 14"x6"  
Lug: MSL-SCTBN  
Hoop: Steel Mighty Hoop (10 Hole)  
Strainer/Butt: MLS50ABN / MLS50BBN  
Snare Wire: MS20RL14C  
Color: Kona Mappa Burl (KMB)

**2.035,00**

## S.L.P. G-MAPLE



Color: Satin Tamo Ash -STA

### LGM137

Shell: 10mm, 11ply Maple + 1 outer ply Tamo Ash  
Size: 13"x7"  
Lug: MTL60  
Hoop: Die-Cast Hoop (8 hole)  
Strainer/Butt: MLS50A/MLS50B  
Snare Wire: MS20SN13C  
Color: Satin Tamo Ash (STA)

**2.252,00**

## S.L.P. G-WALNUT



Color: Matte Black Walnut -MBW

### LGW1465

Shell: 9mm, 10ply Walnut  
Size: 14"x6.5"  
Lug: MTL60  
Hoop: Sound Arc Hoop (10 hole)  
Strainer/Butt: MLS50A/MLS50B  
Snare Wire: MS30R14S  
Color: Matte Black Walnut (MBW)

**1.992,00**

## S.L.P. DUO BIRCH



Color: Transparent Mocha -TPM

### LBH1410L

Shell: 7mm, 7ply Birch  
Size: 14"x10"  
Lug: MSL-SCT  
Hoop: Sound Arc Hoop (8 hole)  
Strainer/Butt: MCS70A/MCS70B  
Snare Wire: MS20R14S  
Color: Transparent Mocha (TPM)  
\*MTB25E Brackets are equipped.  
\*MFLSL3P Legs are Included.

**1.732,00**

## S.L.P. FAT SPRUCE



Color: Wild Satin Spruce -WSS

### LSP146

Shell: 7mm, 8ply Spruce  
Size: 14"x6"  
Lug: MTL60  
Hoop: Die-Cast Hoop (8 hole)  
Strainer/Butt: MLS50A/MLS50B  
Snare Wire: MS20RL14C  
Color: Wild Satin Spruce (WSS), Turquoise (TUQ)

**1.862,00**

## S.L.P. CLASSIC MAPLE



Color: Super Maple -SMP

### LMP1455

Shell: 7mm, 8ply Maple  
Size: 14"x5.5"  
Lug: MTL50  
Hoop: Sound Arc Hoop (10 hole)  
Strainer/Butt: MLS50A/MLS50B  
Snare Wire: MS20RL14C  
Color: Super Maple (SMP)

**1.862,00**

## S.L.P. STUDIO MAPLE



Color: Sienna -SEN

### LMP1465F

Shell: 5mm, 6ply Maple w/ Sound Focus Rings  
Size: 14"x6.5"  
Lug: MSL-SCT  
Hoop: 100% Maple Wood Hoop (8 hole)  
Strainer/Butt: MLS50A/MLS50B  
Snare Wire: MS20SN14S  
Color: Sienna (SEN)

**2.339,00**

## S.L.P. EXPRESSIVE HAMMERED STEEL



### LST146H

Shell: 1.2mm Hammered Steel  
Size: 14"x6"  
Lug: MCHL5BN  
Hoop: 2.3mm Steel Mighty Hoop (10 hole)  
Strainer/Butt: MLS30ABN/MLS30BBN  
Snare Wire: MS20SN14S

**1.862,00**

## S.L.P. DYNAMIC BRONZE



### LBZ1445

Shell: 1.2mm Bronze in Aged finish  
Size: 14"x4.5"  
Lug: MSL-SCPBN  
Hoop: Die-Cast Hoop (8 hole)  
Strainer/Butt: MCS70ABN/MCS70BBN  
Snare Wire: MS20SN14C

**2.600,00**

## S.L.P. BLACK BRASS



### LBR1465

Shell: 1.5mm Brass  
Size: 14"x6.5"  
Lug: MSL-SCTBN  
Hoop: Steel Mighty Hoop (10 hole)  
Strainer/Butt: MLS30ABN/MLS30BBN  
Snare Wire: MS42R14S

**2.600,00**

## S.L.P. BIG BLACK STEEL



### LST148

Shell: 1mm Steel in Matte Black Finish  
Size: 14"x8"  
Lug: MSL35BN  
Hoop: Steel Mighty Hoop (10 hole)  
Strainer/Butt: MLS30ABN/MLS30BBN  
Snare Wire: MS20SN14S

**1.211,00**

## S.L.P. CLASSIC DRY ALUMINUM



### LAL1455

Shell: 1.2mm Seamless Aluminum  
Size: 14"x5.5"  
Lug: MCHL5S  
Hoop: Steel Mighty Hoop (8 hole)  
Strainer/Butt: MLS30A/MLS30B  
Snare Wire: MS20RL14C

**1.732,00**

## METALWORKS



### BST1055MBK

Shell: 1mm Steel  
Size: 10"x5.5"  
Lug: MSL60SBK  
Hoop: Triple Flanged Hoop (6 hole)  
Strainer/Butt: MUS65ABK/MUS60BBK  
Snare Wire: MS16R10S  
\*Tom bracket is equipped.

**603,00**

## METALWORKS



### BST134BK

Shell: 1mm Steel  
Size: 13"x4"  
Lug: MSL-SCPBK  
Hoop: Triple Flanged Hoop (6 hole)  
Strainer/Butt: MCS70ABK/MCS70BBK  
Snare Wire: MS20R13S

**625,00**

## METALWORKS



**BST1455BK**  
 Shell: 1mm Steel  
 Size: 14"x5.5"  
 Lug: MSL60SBK  
 Hoop: Triple Flanged Hoop (8 hole)  
 Strainer/Butt: MUS65ABK/MUS60BBK  
 Snare Wire: MS20R14S

**647,00**

## METALWORKS



**BST1465BK**  
 Shell: 1mm Steel  
 Size: 14"x6.5"  
 Lug: MSL60SBK  
 Hoop: Triple Flanged Hoop (8 hole)  
 Strainer/Butt: MUS65ABK/MUS60BBK  
 Snare Wire: MS20R14S

**690,00**

## METALWORKS EFFECT MINI-TYMP SNARE DRUMS



**BST63MBK**  
 Shell: 1mm Steel  
 Size: 6"x3"  
 Lug: MSL80TBK  
 Hoop: Triple Flanged Hoop (4 hole)  
 Snare Wire: Mod Tone System w/ Snare Wire  
 \*Tom bracket is equipped.  
 \*MC69 single tom attachment is included.

**668,00**

## METALWORKS EFFECT MINI-TYMP SNARE DRUMS



**BST83MBK**  
 Shell: 1mm Steel  
 Size: 8"x3"  
 Lug: MSL80TBK  
 Hoop: Triple Flanged Hoop (4 hole)  
 Snare Wire: Mod Tone System w/ Snare Wire  
 \*Tom bracket is equipped.  
 \*MC69 single tom attachment is included.

**690,00**

## METALWORKS EFFECT MINI-TYMP SNARE DRUMS



**BST103MBK**  
 Shell: 1mm Steel  
 Size: 10"x3"  
 Lug: MSL80TBK  
 Hoop: Triple Flanged Hoop (6 hole)  
 Snare Wire: Mod Tone System w/ Snare Wire  
 \*Tom bracket is equipped.  
 \*MC69 single tom attachment is included.

**733,00**

## METALWORKS EFFECT MINI-TYMP SNARE DRUMS



**BST143MBK**  
 Shell: 1mm Steel  
 Size: 14"x3"  
 Lug: MSL80TBK  
 Hoop: Triple Flanged Hoop (6 hole)  
 Snare Wire: Mod Tone System w/ Snare Wire  
 \*Tom bracket is equipped.  
 \*MC69 single tom attachment is included.

**777,00**

## WOODWORKS



Color: Black Oak Wrap (BOW)

**WP1455BK**  
 Shell: 8mm, 8ply Poplar  
 Size: 14"x5.5"  
 Lug: MSL60SBK  
 Hoop: Triple Flanged Hoop (8 hole)  
 Strainer/Butt: MUS65ABK/MUS60BBK  
 Snare Wire: MS20R14S  
 Color: Natural ZebraWood Wrap (NZW), Black Oak Wrap (BOW)

**625,00**

## WOODWORKS



Color: Natural ZebraWood Wrap (NZW)

**WP1465BK**  
 Shell: 8mm, 8ply Poplar  
 Size: 14"x6.5"  
 Lug: MSL60SBK  
 Hoop: Triple Flanged Hoop (8 hole)  
 Strainer/Butt: MUS65ABK/MUS60BBK  
 Snare Wire: MS20R14S  
 Color: Natural ZebraWood Wrap (NZW), Black Oak Wrap (BOW)

**625,00**

## WOODWORKS



Color: Black Oak Wrap (BOW)

**WP148BK**  
 Shell: 8mm, 8ply Poplar  
 Size: 14"x8"  
 Lug: MSL60SBK  
 Hoop: Triple Flanged Hoop (8 hole)  
 Strainer/Butt: MUS65ABK/MUS60BBK  
 Snare Wire: MS20R14S  
 Color: Natural ZebraWood Wrap (NZW), Black Oak Wrap (BOW)

**668,00**

## SIGNATURE PALETTE -CHARLIE BENANTE



MADE IN JAPAN

**CB1465**  
 Shell: 1.2mm Stainless Steel  
 Size: 14"x6.5"  
 Lug: MSL35BN  
 Hoop: Die-Cast Hoop (10 hole)  
 Strainer/Butt: MLS50ABN/MLS50BBN  
 Snare Wire: MS20SN14S

**2.600,00**

## SIGNATURE PALETTE -STEWART COPELAND



MADE IN JAPAN

**SC145**  
 Shell: 1.5mm Brass  
 Size: 14"x5"  
 Lug: MSL35  
 Hoop: Die-Cast Hoop (10 hole, Batter side)/Steel Mighty Hoop (10 hole, Snare side)  
 Strainer/Butt: MLS50A/MLS50B  
 Snare Wire: MS20SN14S

**2.600,00**

## SIGNATURE PALETTE -PETER ERSKINE



MADE IN JAPAN

**PE106M**  
 Shell: 10mm, 12pcs Stave Ash  
 Size: 10"x6"  
 Lug: MSL90SC  
 Hoop: Die-Cast Hoop (6 Hole)  
 Strainer/Butt: MLS50A / MLS50B  
 Snare Wire: MS20SN10S  
 Super Resonant Mounting System Equipped

**5.160,00**



## SIGNATURE PALETTE -PETER ERSKINE



### PE1445

MADE IN JAPAN

Shell: 6mm, 4ply Spruce + 2 inner ply Maple w/ Sound Focus Ring only for batter side (Same configuration : 6mm, 4ply Spruce + 2 inner ply Maple)  
Size: 14"x4.5"  
Lug: MTL145  
Hoop: 2.3mm Sound Arc Hoop (8 Hole)  
Strainer/Butt: MLS50A / MLS50B  
Snare Wire: MS20RL14C

**2.296,00**

## SIGNATURE PALETTE -MIKE PORTNOY



### MP125ST

MADE IN JAPAN

Shell: 1mm Steel (Hammered Matte Black)  
Size: 12"x5"  
Lug: MSL-SCT  
Hoop: Die-Cast Hoop (6 hole)  
Strainer/Butt: MCS100A/MCS70B  
Snare Wire: MS20SN12S

**2.252,00**

## SIGNATURE PALETTE -MIKE PORTNOY



### MP1455ST

MADE IN JAPAN

Shell: 1mm Steel (Hammered Matte Black)  
Size: 14"x5.5"  
Lug: MSL-SCT  
Hoop: Die-Cast Hoop (8 hole)  
Strainer/Butt: MCS100A/MCS70B  
Snare Wire: MS20SN14S

**2.513,00**

## SIGNATURE PALETTE -MIKE PORTNOY



### MP1455BU

MADE IN JAPAN

Shell: 8mm, 9ply Bubinga  
Size: 14"x5.5"  
Lug: MSL-SCT  
Hoop: Die-Cast Hoop (8 hole)  
Strainer/Butt: MCS100A/MCS70B  
Snare Wire: MS20SN14S

**3.120,00**

## SIGNATURE PALETTE -JOHN TEMPESTA



### JT147

MADE IN JAPAN

Shell: 2mm Brass  
Size: 14"x7"  
Lug: MSL-SCTBN  
Hoop: Die-Cast Hoop (10 hole)  
Strainer/Butt: MLS50ABN/MLS50BBN  
Snare Wire: MS42R14S

**3.771,00**

## SIGNATURE PALETTE -LARS ULRICH



### LU1465N

MADE IN JAPAN

Shell: 3mm Diamond Plate Steel  
Size: 14"x6.5"  
Lug: MSL35  
Hoop: Die-Cast Hoop (10 hole)  
Strainer/Butt: MLS50A/MLS50B  
Snare Wire: MS20SN14S

**3.771,00**



# DRUM PEDALS

Our Iron Cobra pedals have long been praised for being smooth, reliable, and independently adjustable. Iron Cobra pedals are offered in the high end 900 series as well as the standard 600 and 200 models. Speed Cobra 910 and 310 drum pedals feature a longer footboard for a lighter, quicker feel. Our drum pedal range is designed to fit the needs of every drummer.

## DYNA-SYNC SINGLE PEDAL



### HPDS1

- Optimized Transmission Design
- Dual Linkage
- Slidable Cam
- Footboard Angle Adjustment
- Dyna Beater
- Swivel Spring Tight
- Speedo-Ring
- Oiles Bearing Hinge
- Para-Clamp II Pro
- Sync-Coil
- Hinge Guard Block
- Hardshell Carrying Case

**1.601,00**

## DYNA-SYNC TWIN PEDAL



### HPDS1TW

- Optimized Transmission Design
- Dual Linkage
- Slidable Cam
- Footboard Angle Adjustment
- Dyna Beater
- Swivel Spring Tight
- Speedo-Ring
- Oiles Bearing Hinge
- Para-Clamp II Pro
- Sync-Coil
- Hinge Guard Block
- Hardshell Carrying Case

**3.468,00**

## DYNA-SYNC TWIN PEDAL



### HPDS1TWL

- Left-Footed
- Optimized Transmission Design
- Dual Linkage
- Slidable Cam
- Footboard Angle Adjustment
- Dyna Beater
- Swivel Spring Tight
- Speedo-Ring
- Oiles Bearing Hinge
- Para-Clamp II Pro
- Sync-Coil
- Hinge Guard Block
- Hardshell Carrying Case

**3.468,00**

## SPEED COBRA 910 SINGLE PEDAL



### HP910LN

- Long Footboard
- Recessed Setting
- Rolling Glide LiteSprocket Cam
- Accu-Strike Cobra Beater
- Swivel Spring Tight
- Super Stabilizer Design
- Para-Clamp II Pro
- Cobra Coil
- Hinge Guard Block
- Hardshell Carrying Case

**1.211,00**

## SPEED COBRA 910 TWIN PEDAL



### HP910LWN

- Long Footboard
- Recessed Setting
- Rolling Glide LiteSprocket Cam
- Accu-Strike Cobra Beater
- Swivel Spring Tight
- Super Stabilizer Design
- Para-Clamp II Pro
- Cobra Coil
- Hinge Guard Block
- Hardshell Carrying Case

**2.600,00**

## SPEED COBRA 910 TWIN PEDAL



### HP910LWLN

- Left-Footed
- Long Footboard
- Recessed Setting
- Rolling Glide LiteSprocket Cam
- Accu-Strike Cobra Beater
- Swivel Spring Tight
- Super Stabilizer Design
- Para-Clamp II Pro
- Cobra Coil
- Hinge Guard Block
- Hardshell Carrying Case

**2.600,00**

## IRON COBRA 900 SINGLE PEDAL -POWER GLIDE-



### HP900PN

- Power Glide LiteSprocket Cam
- Power-Strike Cobra Beater
- Swivel Spring Tight
- Super Stabilizer Design
- Para-Clamp II Pro
- Cobra Coil
- Hinge Guard Block
- Hardshell Carrying Case

**1.211,00**

## IRON COBRA 900 TWIN PEDAL -POWER GLIDE-



### HP900PWN

- Power Glide LiteSprocket Cam
- Power-Strike Cobra Beater
- Swivel Spring Tight
- Super Stabilizer Design
- Para-Clamp II Pro
- Cobra Coil
- Hinge Guard Block
- Hardshell Carrying Case

**2.600,00**

## IRON COBRA 900 TWIN PEDAL -POWER GLIDE-



### HP900PWLN

- Left-Footed
- Power Glide LiteSprocket Cam
- Power-Strike Cobra Beater
- Swivel Spring Tight
- Super Stabilizer Design
- Para-Clamp II Pro
- Cobra Coil
- Hinge Guard Block
- Hardshell Carrying Case

**2.600,00**

## IRON COBRA 900 SINGLE PEDAL -ROLLING GLIDE-



### HP900RN

- Rolling Glide LiteSprocket Cam
- Power-Strike Cobra Beater
- Swivel Spring Tight
- Super Stabilizer Design
- Para-Clamp II Pro
- Cobra Coil
- Hinge Guard Block
- Hardshell Carrying Case

**1.211,00**

## IRON COBRA 900 TWIN PEDAL -ROLLING GLIDE-



### HP900RWN

- Rolling Glide LiteSprocket Cam
- Power-Strike Cobra Beater
- Swivel Spring Tight
- Super Stabilizer Design
- Para-Clamp II Pro
- Cobra Coil
- Hinge Guard Block
- Hardshell Carrying Case

**2.600,00**

## IRON COBRA 600 SINGLE PEDAL -DUO GLIDE-



### HP600D

- Duo Glide
- Double Chain Drive
- Speedo-Ring
- Para-Clamp
- Spring Tension Adjustment
- Beater Angle Adjustment
- Dual Sided Beater

**647,00**

## IRON COBRA 600 TWIN PEDAL -DUO GLIDE-



### HP600DTW

- Duo Glide
- Double Chain Drive
- Speedo-Ring
- Para-Clamp
- Spring Tension Adjustment
- Beater Angle Adjustment
- Dual Sided Beater

**1.645,00**

## SPEED COBRA 310 SINGLE PEDAL



### HP310L

- Long Footboard
- Recessed Setting
- Rolling Glide LiteSprocket
- Double Chain Drive
- Spring Tension Adjustment
- Beater Angle Adjustment
- Dual Sided Beater

**560,00**

## SPEED COBRA 310 TWIN PEDAL



### HP310LW

- Long Footboard
- Recessed Setting
- Rolling Glide LiteSprocket
- Double Chain Drive
- Spring Tension Adjustment
- Beater Angle Adjustment
- Dual Sided Beater

**1.515,00**

## IRON COBRA 200 SINGLE PEDAL



### HP200P

- Power Glide
- Spring Tension Adjustment
- Beater Angle Adjustment
- Dual Sided Beater

**430,00**

## IRON COBRA 200 TWIN PEDAL



### HP200PTW

- Power Glide
- Spring Tension Adjustment
- Beater Angle Adjustment
- Dual Sided Beater

**1.211,00**

## IRON COBRA 200 TWIN PEDAL



### HP200PTWL

- Left-Footed
- Power Glide
- Spring Tension Adjustment
- Beater Angle Adjustment
- Dual Sided Beater

**1.211,00**

## STANDARD SINGLE PEDAL



### HP30

- Power Glide
- Spring Tension Adjustment
- Beater Angle Adjustment
- Dual Sided Beater

**312,00**

## STANDARD TWIN PEDAL



### HP30TW

- Power Glide
- Spring Tension Adjustment
- Beater Angle Adjustment
- Dual Sided Beater

**690,00**

## THE CLASSIC PEDAL



### HP50

- Center Strike Height Adjust
- Easy Access Spring Adjustment
- The Classic Beater
- Smooth Surface Footboard
- Individual Adjustment of Beater & Footboard Angle
- Easy-Tight Hoop Clamp
- Compact Folding Design

**560,00**

## TWIN PEDAL ATTACHMENT



### TPA90

Specially designed attachment to connect Speed Cobra 910 and Iron Cobra 900 series pedals with Speed Cobra 910 and Iron Cobra 900 series Hi-hat stands.

**65,00**

# HI-HAT STANDS

In addition to bass drum pedals, we offer various hi-hat stands including our high end Dyna-Sync, Iron Cobra & Speed Cobra models as well as our standard Stage Master models.

## DYNA-SYNC HI-HAT STAND



### HHDS1

- Direct Drive Action
- Spring Damper for Reducing Noise
- Quick-Set Hi-Hat Clutch
- 6-way Tension Adjustment
- Footboard Angle Adjustment
- Bigger Rubber Feet w/Duo-Spike
- Weight: 5.2kg (11.7lbs)
- Height Adjustment Range:  
745mm-960mm (29 3/8" - 37 3/4") (Standard Rod) /  
745mm-810mm (29 3/8" - 31 7/8") (Short Rod)

**1.905,00**

## SPEED COBRA 910 HI-HAT STAND - LEVER GLIDE



### HH915D

- Spring Seat
- Quick-Set Hi-Hat Clutch
- 6-way Tension Adjustment
- Bigger Rubber Feet w/Duo-Spike
- Weight: 5.2kg (11.7lbs)
- Height Adjustment Range:  
745mm-960mm (29 3/8" - 37 3/4") (Standard Rod) /  
745mm-810mm (29 3/8" - 31 7/8") (Short Rod)

**1.645,00**

## IRON COBRA 900 HI-HAT STAND -LEVER GLIDE



### HH905D

- Spring Seat
- Quick-Set Hi-Hat Clutch
- 6-way Tension Adjustment
- Bigger Rubber Feet w/Duo-Spike
- Weight: 5.2kg (11.7lbs)
- Height Adjustment Range:  
745mm-960mm (29 3/8" - 37 3/4") (Standard Rod) /  
745mm-810mm (29 3/8" - 31 7/8") (Short Rod)

**1.645,00**

## IRON COBRA 900 HI-HAT STAND -VELO GLIDE



### HH805D

- Spring Seat
- Quick-Set Hi-Hat Clutch
- 6-way Tension Adjustment
- Bigger Rubber Feet w/Duo-Spike
- Weight: 5.2kg (11.7lbs)
- Height Adjustment Range:  
745mm-960mm (29 3/8" - 37 3/4") (Standard Rod) /  
745mm-810mm (29 3/8" - 31 7/8") (Short Rod)

**1.558,00**

## IRON COBRA 900 REMOTE HI-HAT STAND



### HH905RH

- JAGWIRE™ Triple-Layered Ultra-Smooth Cable
- Quick-Set Hi-Hat Clutch
- Lever Glide
- 6-way Tension Adjustment
- MC66 Universal Clamp
- Ratchet Arm (Φ12mm, Arm Length: 200mm)
- Dual Leg
- Cable Holders (x 6)
- Carrying Bag
- Weight: 8.1kg (17lbs)

**2.513,00**

## IRON COBRA 600 HI-HAT STAND



### HH605

- Spring Seat
- Swing Lock Clutch
- 6-way Tension Adjustment
- Swivel Foot
- Direct Pull Action
- Footboard Angle Adjustment
- Weight: 4.3kg (9.7lbs)
- Height Adjustment Range: 710mm-930mm (28" - 36 5/8")

**864,00**

## SPEED COBRA 310 HI-HAT STAND



### HH315D

- Dual Leg
- 28.6mm Diameter Base Section Tubing
- Security Clutch
- 6-way Tension Adjustment
- Swivel Foot
- Direct Pull Action
- Weight: 3.9kg (8.9lbs)
- Height Adjustment Range: 710mm-930mm (28" - 36 5/8")

**712,00**

## IRON COBRA 200 HI-HAT STAND



### HH205

- Double Braced Legs
- 5-way Tension Adjustment
- Swivel Foot
- Direct Pull Action
- Non-Loosening Tension Rod
- Toe Guard
- Security Clutch
- Weight: 3.8kg (8.6lbs)
- Height Adjustment Range: 670mm-930mm (26 3/8" - 36 5/8")

**603,00**

## IRON COBRA 200 HI-HAT STAND



### HH205S

- Single Braced Legs
- 5-way Tension Adjustment
- Swivel Foot
- Direct Pull Action
- Non-Loosening Tension Rod
- Toe Guard
- Security Clutch
- Weight: 3.1kg (6.8lbs)
- Height Adjustment Range: 670mm-930mm (26 3/8" - 36 5/8")

**560,00**

## STAGE MASTER HI-HAT STAND



### HH45WN

- Double Braced Legs
- Swivel Foot
- Direct Pull Action
- Non-Loosening Tension Rod
- Toe Guard
- Security Clutch
- Weight: 3.4kg (7.6lbs)
- Height Adjustment Range: 670mm-930mm (26 3/8" - 36 5/8")

**451,00**

## THE CLASSIC HI-HAT STAND



### HH55F

- Single Braced Flat Base Tripod Legs
- Individual Adjustment of Spring Tension & Footboard Angle
- Knurling on Base Pipe
- Memory Lock
- Weight: 2.3kg (5.1 lbs)
- Height Adjustment Range: 650mm-950mm (24 5/8" - 37 3/8")
- Storage size: 500mm (19 11/16") (upper section) / 600mm (23 5/8") (lower section)

**516,00**



# DRUM THRONES

Being comfortable on your drum set is one of the most important aspects of drumming, making the drum throne a vital yet often overlooked piece of equipment. Our ergonomic 1st Chair Drum Thrones have many original TAMA features to guarantee comfort, stability, and quick, easy setup.

## 1ST CHAIR ROUND RIDER XL DRUM THRONE -CLOTH TOP



### HT850BC

Round Rider XL "Cloth Top" Seat  
 -15" Diameter, 130mm (5 1/8") Thick Round Seat  
 -HYDRAULIX  
 -Seat Lock  
 -Oversized Rubber Feet  
 -Foot Life  
 -Weight: 6.0kg (13.3lbs)  
 -Height Adjustment Range: 515mm - 695mm (21 1/4" - 27 3/8")

**1.298,00**

## 1ST CHAIR ROUND RIDER XL DRUM THRONE



### HT830R

Round Rider XL Seat  
 -15" Diameter, 130mm (5 1/8") Thick Round Seat  
 -1st Chair Height Adjustment  
 -Seat Lock  
 -Glide-Tite Grip Joint  
 -Rocklok  
 -Oversized Rubber Feet  
 -Foot Life  
 -Weight: 6.0kg (13.3lbs)  
 -Height Adjustment Range: 515mm - 670mm (21 1/4" - 26 3/8")

**1.167,00**

## 1ST CHAIR ROUND RIDER XL DRUM THRONE



### HT830B

Round Rider XL Seat  
 -15" Diameter, 130mm (5 1/8") Thick Round Seat  
 -1st Chair Height Adjustment  
 -Seat Lock  
 -Glide-Tite Grip Joint  
 -Rocklok  
 -Oversized Rubber Feet  
 -Foot Life  
 -Weight: 6.0kg (13.3lbs)  
 -Height Adjustment Range: 515mm - 670mm (21 1/4" - 26 3/8")

**1.167,00**

## 1ST CHAIR ERGO-RIDER DRUM THRONE -CLOTH TOP



### HT750BC

Ergo-Rider "Cloth Top" Seat  
 -HYDRAULIX  
 -Seat Lock  
 -Oversized Rubber Feet  
 -Foot Life  
 -Weight: 6.1kg (13.7lbs)  
 -Height Adjustment Range: 505mm - 685mm (19 7/8" - 27")

**1.298,00**

## 1ST CHAIR ERGO-RIDER DRUM THRONE



### HT730B

Ergo-Rider Seat  
 -1st Chair Height Adjustment  
 -Seat Lock  
 -Glide-Tite Grip Joint  
 -Rocklok  
 -Oversized Rubber Feet  
 -Foot Life  
 -Weight: 6.1kg (13.7lbs)  
 -Height Adjustment Range: 505mm - 660mm (19 7/8" - 26")

**1.167,00**

## 1ST CHAIR ERGO-RIDER DRUM THRONE -QUARTET



### HT741B

Ergo-Rider Seat  
 -1st Chair Height Adjustment  
 -Seat Lock  
 -Backrest  
 -Glide-Tite Grip Joint  
 -Rocklok  
 -Oversized Rubber Feet  
 -Foot Life  
 -Weight: 9.4kg (20.1lbs)  
 -Height Adjustment Range: 515mm - 665mm (20 1/4" - 26 3/6")

**1.732,00**

## 1ST CHAIR GLIDE RIDER DRUM THRONE -CLOTH TOP



### HT550BCN

Glide Rider "Cloth Top" Seat  
 -HYDRAULIX  
 -Seat Lock  
 -Glide-Tite Grip Joint  
 -Oversized Rubber Feet  
 -Foot Life  
 -Weight: 5.9kg (13lbs)  
 -Height Adjustment Range: 470mm - 650mm (18 1/2" - 24 5/8")

**1.298,00**

## 1ST CHAIR GLIDE RIDER DRUM THRONE -CLOTH TOP



### HT530BCN

Glide Rider "Cloth Top" Seat  
 -1st Chair Height Adjustment  
 -Seat Lock  
 -Glide-Tite Grip Joint  
 -Rocklok  
 -Oversized Rubber Feet  
 -Foot Life  
 -Weight: 5.9kg (13lbs)  
 -Height Adjustment Range: 470mm - 675mm (18 1/2" - 26 1/2")

**1.167,00**

## 1ST CHAIR WIDE RIDER DRUM THRONE -CLOTH TOP



### HT530BC

Wide Rider "Cloth Top" Seat  
 -1st Chair Height Adjustment  
 -Seat Lock  
 -Glide-Tite Grip Joint  
 -Rocklok  
 -Oversized Rubber Feet  
 -Foot Life  
 -Weight: 6.0kg (13.3lbs)  
 -Height Adjustment Range: 485mm - 640mm (19" - 25 3/16")

**1.167,00**

## 1ST CHAIR WIDE RIDER DRUM THRONE



### HT530B

Wide Rider Seat  
 -1st Chair Height Adjustment  
 -Seat Lock  
 -Glide-Tite Grip Joint  
 -Rocklok  
 -Oversized Rubber Feet  
 -Foot Life  
 -Weight: 6.0kg (13.3lbs)  
 -Height Adjustment Range: 485mm - 640mm (19" - 25 3/16")

**1.167,00**

## 1ST CHAIR ROUND RIDER DRUM THRONE -CLOTH TOP



### HT430BC

Round Rider "Cloth Top" Seat  
 -14" Diameter, 120mm (4 3/4") Thick Round Seat  
 -1st Chair Height Adjustment  
 -Seat Link  
 -Rocklok  
 -Foot Life  
 -Weight: 5.3kg (11.1lbs)  
 -Height Adjustment Range: 485mm - 655mm (19" - 25 3/4")

**820,00**

## 1ST CHAIR ROUND RIDER DRUM THRONE



### HT430B

Round Rider Seat  
 -14" Diameter, 120mm (4 3/4") Thick Round Seat  
 -1st Chair Height Adjustment  
 -Seat Link  
 -Rocklok  
 -Foot Life  
 -Weight: 5.3kg (11.1lbs)  
 -Height Adjustment Range: 485mm - 655mm (19" - 25 3/4")

**820,00**

## 1ST CHAIR SADDLE-TYPE DRUM THRONE



### HT250

Saddle-Type Seat  
 -1st Chair Height Adjustment  
 -Glide-Tite Grip Joint  
 -Rocklok  
 -Foot Life  
 -Weight: 4.05kg (8.9lbs)  
 -Height Adjustment Range: 425mm - 625mm (16 3/4" - 24 1/2")

**668,00**

## 1ST CHAIR ROUNDED TYPE DRUM THRONE



### HT230

Rounded Seat  
 -1st Chair Height Adjustment  
 -Glide-Tite Grip Joint  
 -Rocklok  
 -Foot Life  
 -Weight: 4.0kg (8.8lbs)  
 -Height Adjustment Range: 460mm - 660mm (18" - 26")

**560,00**

## 1ST CHAIR LOW PROFILE ROUNDED TYPE DRUM THRONE



### HT230LOW

Rounded Seat  
 -1st Chair Height Adjustment  
 -Glide-Tite Grip Joint  
 -Rocklok  
 -Foot Life  
 -Weight: 3.6kg (8lbs)  
 -Height Adjustment Range: 374mm - 519mm (15" - 20 1/2")

**560,00**

## STANDARD DRUM THRONE



### HT130

-13" Diameter, 90mm (3 1/2") Thick Round Seat  
 -Double Braced Legs  
 -Weight: 3.4kg (7.7lbs)  
 -Height Adjustment Range: 445mm - 620mm (17 1/2" - 24 7/16")

**386,00**

# SNARE STANDS

Our STAR snare stand has several unique features which provide the ultimate solution for a flexible and stable snare drum setup. Our Roadpro stands now have greater stability, in addition to Quick-Set universal tilters.

## STAR HARDWARE SNARE STAND



### HS100W

For 12" to 15" Diameter Snare Drums  
 -28.6mm Diameter Base Section Tubing  
 -Cradle-Hold Snare Basket  
 -Glide-Tite Grip Joint  
 -True-Sound Insulation Mute  
 -Oversized Rubber Feet with Retractable Spike  
 -Weight: 3.9kg (8.9lbs)  
 -Height Adjustment Range: 400mm - 600mm (15 3/4" - 23 5/8")

**950,00**

## ROADPRO SNARE STAND



### HS800W

For 12" to 15" Diameter Snare Drums  
 -28.6mm Diameter Base Section Tubing  
 -Omni-Ball Tilter  
 -Swiveling Basket  
 -Glide-Tite Grip Joint  
 -Double Braced Legs  
 -Weight: 3.4kg (7.7lbs)  
 -Height Adjustment Range: 495mm - 665mm (19 1/2" - 26 3/8")

**668,00**

## ROADPRO SNARE STAND



### HS80W

For 12" to 15" Diameter Snare Drums  
 -28.6mm Diameter Base Section Tubing  
 -Quick-Set Tilter  
 -Swiveling Basket  
 -Glide-Tite Grip Joint  
 -Double Braced Legs  
 -Weight: 3.2kg (7lbs)  
 -Height Adjustment Range: 495mm - 640mm (19 1/2" - 25 3/16")

**473,00**

## ROADPRO SNARE STAND



### HS80PW

For 10" to 12" Diameter Snare Drums  
 -28.6mm Diameter Base Section Tubing  
 -Quick-Set Tilter  
 -Swiveling Basket  
 -Glide-Tite Grip Joint  
 -Double Braced Legs  
 -Weight: 3.2kg (7lbs)  
 -Height Adjustment Range: 465mm - 610mm (18 5/16" - 24")

**473,00**

## ROADPRO SNARE STAND



### HS80LOW

For 12" to 15" Diameter Snare Drums  
 -28.6mm Diameter Base Section Tubing  
 -Low Position Setting Basket  
 -Quick-Set Tilter  
 -Glide-Tite Grip Joint  
 -Double Braced Legs  
 -Weight: 3.3kg (7.4lbs)  
 -Height Adjustment Range: 385mm - 530mm (15 3/16" - 20 7/8")

**625,00**

## 60 SERIES SNARE STAND



### HS60W

For 12" to 15" Diameter Snare Drums  
 -25.4mm Diameter Base Section Tubing  
 -Quick-Set Tilter  
 -Swiveling Basket  
 -Double Braced Legs  
 -Weight: 2.6kg (5.11lbs)  
 -Height Adjustment Range: 470mm - 600mm (18 1/2" - 23 5/8")

**430,00**

## STAGE MASTER SNARE STAND



### HS40WN

For 12" to 15" Diameter Snare Drums  
 -25.4mm Diameter Base Section Tubing  
 -Universal Gearless Tilter  
 -Swiveling Basket  
 -Double Braced Legs  
 -Weight: 2.6kg (5.11lbs)  
 -Height Adjustment Range: 470mm - 630mm (18 1/2" - 24 13/16")

**343,00**

## STAGE MASTER SNARE STAND



### HS40PWN

For 10" to 12" Diameter Snare Drums  
 -25.4mm Diameter Base Section Tubing  
 -Universal Gearless Tilter  
 -Swiveling Basket  
 -Double Braced Legs  
 -Weight: 2.6kg (5.11lbs)  
 -Height Adjustment Range: 470mm - 630mm (18 1/2" - 24 13/16")

**343,00**

## STAGE MASTER SNARE STAND



### HS40SN

For 12" to 15" Diameter Snare Drums  
 -25.4mm Diameter Base Section Tubing  
 -Universal Gearless Tilter  
 -Swiveling Basket  
 -Single Braced Legs  
 -Weight: 2.5kg (5.8lbs)  
 -Height Adjustment Range: 470mm - 630mm (18 1/2" - 24 13/16")

**343,00**

## STAGE MASTER SNARE STAND



### HS40LOWN

For 12" to 15" Diameter Snare Drums  
 -25.4mm Diameter Base Section Tubing  
 -Low Position Setting Basket  
 -Universal Gearless Tilter  
 -Double Braced Legs  
 -Weight: 2.7kg (5.15lbs)  
 -Height Adjustment Range: 370mm - 530mm (14 9/16" - 20 7/8")

**343,00**

## THE CLASSIC SNARE STAND



### HS50S

For 12" to 15" Diameter Snare Drums  
 -19.1mm Diameter Base Section Tubing  
 -Single Braced Tripod Legs  
 -Classic Style Basket  
 -Double Braced Arms  
 -Gearless Tilter  
 -Memory Lock  
 -Weight: 1.7kg (3.11lbs)  
 -Height Adjustment Range: 390mm-580mm (15 3/8" - 22 7/8")  
 -Storage size: 600mm (23 5/8")

**365,00**

# CYMBAL STANDS

The TAMA STAR Hardware cymbal stand is incredibly flexible with several groundbreaking adjustment features. The Roadpro cymbal stands benefit from greater stability, and include the same great Quick-Set Tilter and Quick-Set Cymbal Mates.

## STAR HARDWARE CYMBAL STAND



### HC103BW

-28.6mm Diameter Base Section Tubing  
 -Orbital Quick-Tite Cymbal/Boom Tilter  
 -Glide-Tite Grip Joint  
 -True-Sound Insulation Mute  
 -Ring-True Cymbal Felt  
 -Boom Arm Length: 450mm (17 3/4")  
 -Weight: 6.1kg (13.7lbs)  
 -Height Adjustment Range: 890mm - 2,090mm (35" - 82 1/4")

**1.189,00**

## ROADPRO CYMBAL STAND



### HC84BW

-28.6mm Diameter Base Section Tubing  
 -Quick-Set Tilter  
 -Quick-Set Cymbal Mate  
 -Boom/Straight Convertible Tilter  
 -Glide-Tite Grip Joint  
 -Detachable Counter Weight  
 -Boom Arm Length : 688mm (27 3/32")  
 -Weight : 6.2kg (13.10lbs)  
 -Height Adjustment Range: 820mm - 2,200mm (32 1/4" - 86 5/8")

**690,00**

## ROADPRO CYMBAL STAND



### HC83BW

-28.6mm Diameter Base Section Tubing  
 -Quick-Set Tilter  
 -Quick-Set Cymbal Mate  
 -Boom/Straight Convertible Tilter  
 -Glide-Tite Grip Joint  
 -Double Braced Legs  
 -Boom Arm Length: 450mm (17 3/4")  
 -Weight: 5.0kg (11lbs)  
 -Height Adjustment Range: 820mm - 2,100mm (32 1/4" - 82 5/8")

**516,00**

## ROADPRO CYMBAL STAND



### HC82W

-28.6mm Diameter Base Section Tubing  
 -Quick-Set Tilter  
 -Quick-Set Cymbal Mate  
 -Glide-Tite Grip Joint  
 -Double Braced Legs  
 -Weight: 4.2kg (9.4lbs)  
 -Height Adjustment Range: 740mm - 1,610mm (29 1/8" - 72 7/8")

**451,00**



## ROADPRO LIGHT CYMBAL STAND



### HC83BLS

- 25.4mm Diameter Base Section Tubing
- Quick-Set Tilter
- Quick-Set Cymbal Mate
- Boom/Straight Convertible Tilter
- Glide-Tite Grip Joint
- Single Braced Legs
- Boom Arm Length: 400mm (15 3/4")
- Weight: 3.8kg (8.6lbs)
- Height Adjustment Range: 790mm - 1,850mm (31 1/8" - 72 7/8")

**516,00**

## ROADPRO LIGHT CYMBAL STAND



### HC82LS

- 25.4mm Diameter Base Section Tubing
- Quick-Set Tilter
- Quick-Set Cymbal Mate
- Glide-Tite Grip Joint
- Single Braced Legs
- Weight: 3.1kg (6.13lbs)
- Height Adjustment Range: 710mm - 1,410mm (28" - 55 1/2")

**451,00**

## 60 SERIES CYMBAL STAND



### HC63BW

- 25.4mm Diameter Base Section Tubing
- Quick-Set Tilter
- Boom/Straight Convertible Tilter
- Double Braced Legs
- Boom Arm Length: 400mm (15 3/4")
- Weight: 3.9kg (8.9lbs)
- Height Adjustment Range: 850mm - 2,010mm (33 1/2" - 79 1/8")

**473,00**

## STAGE MASTER CYMBAL STAND



### HC43BWN

- 25.4mm Diameter Base Section Tubing
- Fine Gear Tilter
- Quick-Set Cymbal Mate
- Boom/Straight Convertible Tilter
- Double Braced Legs
- Boom Arm Length: 400mm (15 3/4")
- Weight: 3.4kg (7.5lbs)
- Height Adjustment Range: 760mm - 1,800mm (30" - 70 13/16")

**365,00**

## STAGE MASTER CYMBAL STAND



### HC43BSN

- 25.4mm Diameter Base Section Tubing
- Fine Gear Tilter
- Quick-Set Cymbal Mate
- Boom/Straight Convertible Tilter
- Single Braced Legs
- Boom Arm Length: 400mm (15 3/4")
- Weight: 3.4kg (7.7lbs)
- Height Adjustment Range: 760mm - 1,800mm (30" - 70 13/16")

**365,00**

## STAGE MASTER CYMBAL STAND



### HC42WN

- 25.4mm Diameter Base Section Tubing
- Fine Gear Tilter
- Quick-Set Cymbal Mate
- Double Braced Legs
- Weight: 2.9kg (6.6lbs)
- Height Adjustment Range: 690mm - 1,420mm (27 1/8" - 55 15/16")

**321,00**

## STAGE MASTER CYMBAL STAND



### HC42SN

- 25.4mm Diameter Base Section Tubing
- Fine Gear Tilter
- Quick-Set Cymbal Mate
- Single Braced Legs
- Weight: 2.7kg (5.15lbs)
- Height Adjustment Range: 690mm - 1,420mm (27 1/8" - 55 15/16")

**321,00**

## THE CLASSIC CYMBAL STAND



### HC52F

- 19.1mm Diameter Base Section Tubing
- Flat Base Leg Design
- 9mm Diameter Solid Upper Portion
- Fine Gear Tilter
- Compact Folding Design (580mm 22 27/32")
- Weight 1.48kg (3.2lbs)
- Height Adjustment Range: 590mm - 1,300mm (23 1/4" - 51 3/16")

**312,00**

# TOM STANDS & TOM HOLDERS

TAMA's tom stands and tom holders feature our original Omni-Ball system which allows each tom to be held securely in place. You can position the drum at virtually any angle simply by loosening one T-nut.

## STAR HARDWARE COMBINATION STAND



### HTC107W

- 28.6mm Diameter Base Section Tubing
- Swivel-Wing Tom Holder
- Orbital Quick-Tite Cymbal Tilter
- Orbital Quick-Tite Boom Tilter
- Glide-Tite Grip Joint
- True-Sound Insulation Mute
- Ring-True Cymbal Felt
- Boom Arm Length: 300mm (11 3/4")
- Weight: 7.2kg (15.13lbs)

**1.450,00**

## STAR HARDWARE DOUBLE TOM STAND



### HTW109W

- 28.6mm Diameter Base Section Tubing
- Swivel-Wing Tom Holder
- Stilt System
- Glide-Tite Grip Joint
- Extra Heavy Double Braced Legs
- Weight: 6.0kg (13lbs)
- Height Adjustment Range: 750mm-1,170mm (29 1/2" – 46")

**1.167,00**

## STAR HARDWARE SINGLE TOM STAND



### HTS108W

- For up to 10" Depth Tom Tom
- 28.6mm Diameter Base Section Tubing
- Omni-Ball Tilter
- Glide-Tite Grip Joint
- True-Sound Insulation Mute
- Extra Heavy Double Braced Legs
- Oversized Rubber Feet with Retractable Spike
- Weight: 4.3kg (9.7lbs)
- Height Adjustment Range: 740mm – 1,020mm (29 1/8" – 40 1/8")

**994,00**

## ROADPRO COMBINATION STAND



### HTC807W

- 28.6mm Diameter Base Section Tubing
- Omni-Ball Tom Angle Adjustment / Movable Tom Positioning
- Quick-Set Tilter
- Quick-Set Cymbal Mate
- Glide-Tite Grip Joint
- Double Braced Legs
- Boom Arm Length: 300mm (11 3/4")
- Weight: 5.4kg (11.14lbs)

**950,00**

## ROADPRO COMBINATION STAND



### HTC87W

- 28.6mm Diameter Base Section Tubing
- Omni-Ball Tom Angle Adjustment
- Quick-Set Tilter
- Quick-Set Cymbal Mate
- Glide-Tite Grip Joint
- Double Braced Legs
- Boom Arm Length: 300mm (11 3/4")
- Weight: 5.5kg (12.2lbs)

**864,00**

## ROADPRO DOUBLE TOM STAND



### HTW839W

- 28.6mm Diameter Base Section Tubing
- Omni-Ball Tom Angle Adjustment
- Stilt System
- Glide-Tite Grip Joint
- Double Braced Legs
- Weight: 5.0kg (11lbs)
- Height Adjustment Range: 790-1,270mm (31 1/8" – 50")

**1.081,00**

## ROADPRO DOUBLE TOM STAND



### HTW849W

- 28.6mm Diameter Base Section Tubing
- Omni-Ball Tom Angle Adjustment
- Glide-Tite Grip Joint
- Double Braced Legs
- Low Profile Tetrapod
- Weight: 5.1kg (11.3lbs)
- Height Adjustment Range: 550-800mm (21 5/8" – 31 1/2")

**1.167,00**

## ROADPRO SINGLE TOM STAND



### HTS88W

- 28.6mm Diameter Base Section Tubing
- Omni-Ball Tom Angle Adjustment
- Glide-Tite Grip Joint
- Double Braced Legs
- Height Adjustment Range: 760mm-1,240mm (30" – 49")
- Weight: 4.2kg (9.25lbs)

**582,00**

## STAGE MASTER DOUBLE TOM STAND



### HTW49WN

- 25.4mm Diameter Base Section Tubing
- Omni-Ball Tom Angle Adjustment
- Double Braced Legs
- Weight: 3.6kg (7.14lbs)
- Height Adjustment Range: 770-1,200mm (30 5/16" – 47 1/4")

**516,00**

## THE CLASSIC TOM STAND



### HTS58F

- For 10" to 14" Diameter Drums
- 19.1mm Diameter Base Section Tubing
- Flat Base Leg Design
- Classic Style Basket
- Memory Lock
- Weight: 1.8kg (3.15lbs)
- Height Adjustment Range: 565mm - 820mm (22 1/4" - 32 1/4")
- Storage size: 600mm (23 5/8") (upper section) / 410mm (16 1/8") (lower section)

**365,00**

## DOUBLE TOM HOLDER



### MTH1000

- 25.4mm Diameter Bass Section Tubing
- Swivel-Wing Tom Holder

MTH1000 (chrome)  
MTH1000BN (black nickel)  
MTH1000U (smoked black nickel)

**985,00**

## DOUBLE TOM HOLDER



### MTH800

- 25.4mm Diameter Tubing

**799,00**

## DOUBLE TOM HOLDER



### MTH600

- 25.4mm Diameter Tubing

MTH600 (chrome)  
MTH600BN (black nickel)

**473,00**

## SINGLE TOM HOLDER



### MTH1000S

- 25.4mm Diameter Bass Section Tubing
- Swivel-Wing Tom Holder

MTH1000S (chrome)  
MTH1000SBN (black nickel)  
MTH1000SU (smoked black nickel)

**868,00**

## SINGLE TOM HOLDER



### MTH900BS

- 25.4mm Diameter Bass Section Tubing

**690,00**

## SINGLE TOM HOLDER



### MTH900BM

- 25.4mm Diameter Tubing

**516,00**

## SINGLE TOM HOLDER



### MTH800S

- 25.4mm Diameter Tubing

**608,00**

## ROADPRO ELECTRONIC PAD STAND



### HPS80W

- Glide-Tite Grip Joint
- Double Braced Tripod Base
- Weight: 3.7kg
- Height: 520mm - 1,020mm (20 1/2" - 40 1/8")

**473,00**

# HARDWARE KITS

We offer various hardware kit packages to complement any drum sets.

## IRON COBRA 900 HARDWARE KIT



### HG5WN

- HS800W Roadpro Snare Stand
- HC83BW Roadpro Boom Cymbal Stands (x2)
- HH905D Iron Cobra Hi-hat Stand
- HP900PN Iron Cobra Power Glide Single Pedal

**3.685,00**

## IRON COBRA 600 HARDWARE KIT



### HV5WN

- HS80W Roadpro Snare Stand
- HC83BW Roadpro Boom Cymbal Stands (x2)
- HH605 Iron Cobra 600 Hi-hat Stand
- HP600D Iron Cobra 600 Single Pedal

**2.600,00**

## IRON COBRA 200 HARDWARE KIT



### HB5W

- HS60W Snare Stand
- HC63BW Boom Cymbal Stands (x2)
- HH205 Iron Cobra 200 Hi-hat Stand
- HP200P Iron Cobra 200 Single Pedal

**1.949,00**

## STAGE MASTER HARDWARE KIT



### SM5W

- HS40WN Stage Master Snare Stand
- HC43BWN Stage Master Boom Cymbal Stands (x2)
- HH205 Iron Cobra 200 Hi-hat Stand
- HP200P Iron Cobra 200 Single Pedal

**1.515,00**

## THE CLASSIC STAND HARDWARE KIT



### HC4FB

- HS50S Snare Stand
- HC52F Straight Cymbal Stands (x2)
- HH55F Hi-Hat Stand
- SBH01 Hardware Bag

**1.515,00**

## IRON COBRA 200 BUNDLE WITH 1st CHAIR THRONE



### HED3R

- HP200P Iron Cobra 200 Single Pedal
- HT230 1st Chair Drum Throne (Round seat)
- HH205S Iron Cobra 200 Hi-hat Stand

**1.341,00**

## IRON COBRA 200 BUNDLE WITH 1st CHAIR THRONE



### HED3G

- HP200P Iron Cobra 200 Single Pedal
- HT250 1st Chair Drum Throne (Saddle seat)
- HH205S Iron Cobra 200 Hi-hat Stand

**1.428,00**

## IRON COBRA 200 BUNDLE WITH 1st CHAIR THRONE



### HED2R

- HP200P Iron Cobra 200 Single Pedal
- HT230 1st Chair Drum Throne (Round seat)

**907,00**



## IRON COBRA 200 BUNDLE WITH 1st CHAIR THRONE



### HED2G

-HP200P Iron Cobra 200 Single Pedal  
-HT250 1st Chair Drum Throne (Saddle seat)

**994,00**

## ROADPRO BOOM STAND 2PCS PACK



### HC83BWX2

-HC83BW Roadpro Boom Cymbal Stands (x2)

**864,00**

## STAGE MASTER BOOM STAND 2PCS PACK



### HC43BWNX2

-HC43BWN Stage Master Boom Cymbal Stands (x2)

**690,00**

## THE CLASSIC STAND 2PCS PACK

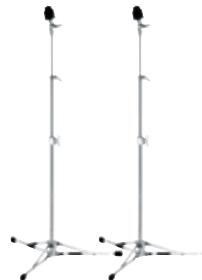

### HC52FX2

-HC52F Straight Cymbal Stands (X2)

**560,00**

# POWER TOWER SYSTEM

TAMA's Power Tower System allows you to maintain the same precise set-up time after time. It utilizes 38.1mm stainless round pipes which allow for drums and hardware to be set-up at any angle quickly and easily.

## POWER TOWER SYSTEM BASIC UNIT



### PMD1100M

- 1100mm Curved Pipe x 1pc
- 850mm Straight Pipe w/19.1mm diameter Joint x 2pc
- 40mm x 20mm x 450mm Square Pipe x 2pc
- Leg Joint Bracket x 2pc
- Rubber Foot x 4pc
- Cross Joint Bracket (J30TS) x 2pc
- Multi Holder (J34T) x 2pc
- Memory Lock (A13S) x 4pc

**2.383,00**

## POWER TOWER SYSTEM ADDITIONAL UNIT



### PMD1100A

- 1100mm Curved Pipe x 1pc
- 850mm Straight Pipe w/19.1mm diameter Joint x 1pc
- 40mm x 20mm x 450mm Square Pipe x 1pc
- Leg Joint Bracket x 1pc
- Rubber Foot x 2pc
- Cross Joint Bracket (J30TS) x 2pc
- Multi Holder (J34T) x 1pc
- Memory Lock (A13S) x 3pc

**1.688,00**

## POWER TOWER SYSTEM ADDITIONAL UNIT



### PMD900A

- 900mm Curved Pipe x 1pc
- 850mm Straight Pipe w/19.1mm diameter Joint x 1pc
- 40mm x 20mm x 450mm Square Pipe x 1pc
- Leg Joint Bracket x 1pc
- Rubber Foot x 2pc
- Cross Joint Bracket (J30TS) x 2pc
- Multi Holder (J34T) x 1pc
- Memory Lock (A13S) x 3pc

**1.601,00**

## CROSS JOINT BRACKET



### J30TS

90 degree perpendicular pipe clamp that allows horizontal and vertical pipes to be set at an equal height.

**213,00**

## MULTI HOLDER



### J34T

Rack mount for L-rods, tom or cymbal holders. Fits pipes from 10.5mm to 28.6mm in diameter.

**213,00**

## MEMORY LOCK



### A13S

Memory clamp designed specifically for the Power Tower System.

**65,00**

## SINGLE TOM HOLDER



### MTH900BS

A single tom holder with 25.4mm diameter base tube.

**690,00**

# CLAMPS AND ATTACHMENTS

Back in the 1970's TAMA's original introduction of the multi-clamp was a real revolution in the complex instrument we know as the drum kit. Today, multi-clamps are standard equipment in drums of all brands.

## UNIVERSAL CLAMP



### MC66

One side can hold pipes with diameters from 15.9mm to 28.6mm, while the other side is a ratchet holder that can hold a rod from 9mm to 12mm in diameter at various angles. An excellent clamp for adding an array of new set-up possibilities.

**204,00**

## UNIVERSAL CLAMP



### MC67

The heavier duty version of the MC66. One side holds pipes with diameters from 15.9mm to 28.6mm, while the other side is a ratchet holder that can hold a 12mm to 25.4 mm diameter rod or pipe at various angles.

**252,00**

## UNIVERSAL CLAMP



### MC56

This clamp can be attached to an existing stand pipe that is 15.9mm to 28.6mm in diameter. By attaching a L-Rod or cymbal boom arm that is 9mm to 12mm in diameter, you can easily add a cowbell, woodblock, or cymbal to your drum kit.

**165,00**

## MULTI-CLAMP



### MC61

A basic clamp for connecting stands with pipes from 15.9mm to 28.6mm in diameter with any attachment having a 19.1mm diameter pipe.

**139,00**

## MULTI-CLAMP



### MC62

A double multi-clamp for connecting two pipes from 15.9mm to 28.6mm in diameter. Both sides feature the FastClamp Easy Set-Up System.

**195,00**

## COMPACT CLAMP



### MC7

Same function as the MC5, but with even greater flexibility. The ratchet holder section can hold any diameter tube from 12mm to 25.4mm.

**195,00**

## HOOP GRIP



### MC8

The Hoop Grip is a simple tool that allows you to add cymbals or other accessories to your drum kit to expand your setup and customize your sound.

-available on Steel Hoops and Die-Cast Hoops.  
\*NOT available on Wood Hoops.

**152,00**

## HOOP GRIP FOR BASS DRUM



### MC9

The MC9 Hoop Grip for bass drum is a simple clamp. However, when combined with an L-Rod or Z-Rod, you can set splash cymbal or various percussion items on the bass drum.

**165,00**

## Z-ROD FOR COWBELL



### ZCB

Z-rod for mounting cowbell or other percussion instruments and accessories (9mm diameter)

**82,00**

## Z-ROD FOR SPLASH CYMBAL -LONG



### ZCYEL

Z-rod for mounting lightweight cymbals (10.5mm diameter)

Details:  
- Quick-set cymbal mate

**113,00**

## Z-ROD FOR SPLASH CYMBAL -SHORT



### ZCYS

Z-rod for mounting lightweight cymbals (10.5mm diameter)

Details:  
- Quick-set cymbal mate

**109,00**

## HOOP GRIP & ACCESSORY MOUNT ARM



### MC8HCA20

Hoop Grip (MC8) & Accessory Mount Arm bundle package

**256,00**

## CLOSED HI-HAT ATTACHMENT



### MXA43

This closed hi-hat attachment utilizes a specially designed screw clutch, allowing for quick, easy, and precise adjustments. The space between the hi-hat cymbals can be adjusted by rotating the screw clutch clockwise or counterclockwise.

**321,00**

## CLOSED HI-HAT ATTACHMENT



### MXA53

Simply designed closed hi-hat attachment that allows for two different settings by turning a lever. Attachable to stands from 15.9mm to 28.6mm in diameter. Great for double bass or double pedal players.

**421,00**

## CLOSED HI-HAT ATTACHMENT



### MXA73N

The tension adjustment knob makes it possible to finely adjust the degree of opening of the hi-hat cymbals. In addition, the angle of the bottom cymbal is also adjustable.

- Quick-set hi-hat clutch  
- Quick-set tilter

**586,00**

## ELECTRONIC PAD HOLDER



### MPH63

The MPH63 is a Fast-Clamp attachment for an electronic pad. Combining TAMA's MC66 universal clamp and the electronic pad stand boom arm, you can attach an electronic pad to any stand that has a 15.9mm to 28.6mm diameter pipe.

**386,00**

## L-ROD FOR TOM TOM



### LLT

L-rod for mounting toms (10.5mm diameter).

**74,00**

## L-ROD FOR COWBELL



### LCB

L-rod for mounting different hand percussion instruments and accessories. The 9mm diameter rod fits most popular percussion instruments designed for attachment to a 3/8" rod.

**69,00**



## L-ROD FOR CYMBAL



### LCYE

L-rod for mounting lightweight cymbals.

Details:  
- Quick-set cymbal mate

**82,00**

## L-ROD FOR HI-HAT CYMBAL



### LHH

L-Rod for Hi-hat cymbals.

Details:  
- Screw-Type Hi-hat clutch

**213,00**

## HAT STACK



### CSH5

- Easily attach a small cymbal to hi-hat rod measuring up to 7mm in diameter  
- Compact size and lightweight for easy transport and storage - 25mm (1") diameter x 40mm (1.5") height  
- Ability to adjust cymbal sustain

**65,00**

## CYMBAL STACKER



### CSA15

The CSA15 is a straight-forward cymbal stacker useful for adding small cymbals to your setup using the M8 threaded cymbal rod.

**113,00**

## CYMBAL STACKER



### CSA25

The CSA25 allows positioning of a small cymbal on the M8 threaded cymbal rod, as well as independent angle adjustment.

**213,00**

## BOOM ARM



### MCB30EN

MCB30EN can be used in combination with a ratchet arm or the MC66 universal clamp is available.

Details:  
- 300mm (11 3/4") length  
- Quick-set tilter  
- Quick-set cymbal mate

**200,00**

## BOOM ARM



### MCB45EN

MCB45EN can be used in combination with a ratchet arm or the MC66 universal clamp is available.

Details:  
- 450mm (17 3/4") length  
- Quick-set tilter  
- Quick-set cymbal mate

**213,00**

## CYMBAL HOLDER



### CACLJ

Bass Drum Mounted Cymbal Holder features telescoping arm & fine gear tilter, which allow you to adjust the angle and height of the cymbal as you like in smaller spaces.

**195,00**

## CYMBAL HOLDER



### CA30EN

Details:  
- 300mm (11 3/4") length  
- Quick-set tilter  
- Quick-set cymbal mate

**378,00**

## CYMBAL HOLDER



### CA45EN

Details:  
- 450mm (17 3/4") length  
- Quick-set tilter  
- Quick-set cymbal mate

**404,00**

## CYMBAL ATTACHMENT



### CCA30

The assortment of boom cymbal holder and MC61 multi-clamp. By connecting to stands from 15.9mm to 28.6mm in diameter, you can add any cymbal easily.

**378,00**

## CYMBAL ATTACHMENT



### MCA53

The MCA53 is a simplified attachment based on the functionality of the MCA63EN. Add cymbals by securing this attachment to stands from 15.9mm to 28.6mm in diameter.

**265,00**

## CYMBAL ATTACHMENT



### MCA63EN

Combines the MC66 universal clamp and the MCB30EN boom arm. Works perfectly for adding cymbals and accessories to stands with pipes from 15.9mm to 28.6mm in diameter.

Details:  
- Quick-set tilter  
- Quick-set cymbal mate

**386,00**

## CYMBAL ATTACHMENT



### CYA5E

Combines the MC5 compact clamp with the LCYE L-rod for mounting one cymbal to one boom arm. Can be clamped to rods from 9mm to 12mm in diameter or to the L-rod of a tom holder.

Details: Quick-set cymbal mate

**213,00**

## TOM ATTACHMENT



### MC69

Clamping this attachment on a 15.9mm to 28.6mm diameter pipe allows for direct set-up of toms. Even with a compact construction, the inclusion of the Omni-ball feature at the angle adjustment point lets you adjust toms to any angle.

**265,00**

## TOM ADAPTER



### MTH900AS

This adapter allows you to add single toms to stands using the flexibility and speed of TAMA's Omni-Ball/L-rod combination.

**213,00**

## COWBELL ATTACHMENT



### CBA5

Compact attachment for mounting hand percussion such as cowbells or tambourines. Combines the MC5 compact clamp and the LCB L-rod to provide set-up flexibility. The 3/8" L-rod fits most popular percussion instruments and accessories.

**191,00**

## COWBELL ATTACHMENT



### CBA56

Combines the universal clamp with the LCB L-rod to mount most popular percussion instruments and accessories. Can be attached to pipes ranging from 15.9 mm to 28.6 mm in diameter.

**200,00**

## COWBELL ATTACHMENT



### CBH20

This simple attachment allows cowbells to be mounted on the bass drum. The length and angle of the L-rod can be easily changed for optimum positioning.

**139,00**

## COWBELL ATTACHMENT



### CBH50

The position and angle of the cowbell are adjustable to your preference. The bass drum clamp is now equipped with rubber hoop protectors in order to prevent the hoop from becoming damaged.

**195,00**

## HI-HAT ATTACHMENT



### MHA823

This hi-hat attachment allows for better positioning of a hi-hat stand while using a double bass drum set-up. By connecting the MHA823 to the bass drum hoop, the hi-hat stand can be held upright without opening the hi-hat stand's legs. By utilizing TAMA Omni-Ball system, the clamp is now infinitely adjustable to any angle and enables even greater set-up flexibility. As well, rubber cushions are equipped to protect bass drum hoop from becoming damaged. The clamp is attachable to any hi-hat stand with a pipe diameter of 15.9 - 28.6mm by using the FastClamp Easy Set-Up System.

**421,00**

## CYMBAL ATTACHMENT KIT



### MCAX5366

A cymbal attachment kit is available for the Cocktail-JAM. These attachments have been simplified for portability. The hi-hat attachment allows you to open or close the hi-hats by simply flipping a lever.

- MCA53 cymbal attachment
- MCA56 closed hi-hat attachment

**603,00**

# MICROPHONE STANDS

Just as many years ago, TAMA single-handedly altered the essence of the modern drum set through its re-invention of drum hardware—TAMA now turns that same degree of engineering dedication to yet another unevolved category of music gear: the microphone stand.

## IRON WORKS STUDIO TELESCOPING BOOM STAND



### MS737BK

- Vice-Grip Boom Tilter
  - Sure-Cast Adjustment Collar
  - Die-Cast Locking Thumb Nut
  - Silent T-Handle
  - Latch-Lok Sleeve Insert
- Height: 995mm - 1,665mm (39 3/16" - 65 1/2")  
 Boom Arm: 1,055mm (41 1/2")  
 Weight: 5.75kg  
 Black Finish

**560,00**

## IRON WORKS STUDIO TELESCOPING BOOM STAND



### MS736BK

- Vice-Grip Boom Tilter
  - Iron-Core Legs with Vibration-Isolating Rubber Feet
  - Iron-Core Telescoping Boom Arm
  - Silent T-Handle
  - Detachable Boom Arm
- Height: 975-1650mm (38 3/8"-64 15/16")  
 Boom arm : 505-850mm (19 7/8"-33 7/16")  
 Weight : 5.4kg (11.9lbs)  
 Black Finish

**560,00**

## IRON WORKS STUDIO LOW PROFILE TELESCOPING BOOM STAND



### MS736LBK

- Vice-Grip Boom Tilter
  - Iron-Core Legs with Vibration-Isolating Rubber Feet
  - Iron-Core Telescoping Boom Arm
  - Silent T-Handle
  - Detachable Boom Arm
- Height : 440mm - 605mm (17 5/16"- 23 13/16")  
 Boom arm : 505mm - 850mm (19 7/8"- 33 7/16")  
 Weight : 4.7kg (10.4lbs)  
 Black Finish

**560,00**

## IRON WORKS STUDIO ROUND BASE TELESCOPING BOOM STAND



### MS736RBK

- Vice-Grip Boom Tilter
  - Sure-Cast Adjustment Collar
  - Die-Cast Locking Thumb Nut
  - Round Cast Base
  - Silent T-Handle
  - Latch-Lok Sleeve Insert
  - Iron-Core Telescoping Boom Arm
- Height: 990-1700mm (38 3/8"-64 15/16")  
 Weight: 8.2kg  
 Black Finish

**560,00**

## IRON WORKS STUDIO ROUND BASE EXTRA LOW PROFILE TELESCOPING BOOM STAND



### MS736RELBK

- Vice-Grip Boom Tilter
  - Iron-Core Telescoping Boom Arm
  - Silent T-Handle
  - Detachable Boom Arm
  - Heavy Round Cast Base
- Height : 280mm (11 1/32")  
 Boom arm : 505mm - 850mm (19 7/8"- 33 7/16")  
 Weight : 7.7kg (17.0lbs)  
 Black Finish

**560,00**

## IRON WORKS STUDIO SERIES EXTRA LOW TELESCOPING BOOM STAND



### MS734ELBK

- Vice-Grip Boom Tilter
  - Die-Cast Locking Thumb Nut
  - Silent T-Handle
  - Iron-Core Telescoping Boom Arm
- Height: 325mm (12 3/4")  
 Boom arm: 335mm - 520mm (13 1/8" - 20 1/2")  
 Weight: 4kg (8.8lbs)  
 Black Finish

**560,00**

## IRON WORKS TOUR TELESCOPING BOOM STAND



### MS436BK

- Cast Grip Boom Tilter
- Die-Cast Locking Thumb Nut
- Sure-Cast Adjustment Collar
- Iron-Core Telescoping Boom Arm
- Detachable Boom Arm

Height : 985mm – 1660mm (38 3/4"– 65 3/8")  
 Boom arm : 845mm (33 1/4")  
 Weight : 3.9kg (8.6lbs)  
 Black Finish

**430,00**

## IRON WORKS TOUR LOW PROFILE TELESCOPING BOOM STAND



### MS436LBK

- Cast Grip Boom Tilter
- Die-Cast Locking Thumb Nut
- Sure-Cast Adjustment Collar
- Iron-Core Telescoping Boom Arm
- Detachable Boom Arm

Height : 440mm – 605mm (17 5/16"– 23 13/16")  
 Boom arm : 505mm (19 7/8"– 33 1/4")  
 Weight : 3.1kg (6.9lbs)  
 Black Finish

**430,00**

## IRON WORKS TOUR TABLE TOPSTAND



### MS30BK

- Lighter Smaller Zinc Die-Cast Round Base
- 2 stage Aluminum Pipe Construction

Height: 220mm - 370mm (8 5/8"-14 9/16")  
 Weight: 1.1kg  
 Black Finish

**169,00**

## BOOM STAND



### MS205

- Cast Grip Boom Tilter

Height : 960mm – 1600mm (37 13/16"– 63")  
 Boom arm : 830mm (32 11/16")  
 Weight : 3.2kg (7.1 lbs)  
 Chrome Finish

**356,00**

## BOOM STAND



### MS205BK

- Cast Grip Boom Tilter

Height : 960mm – 1600mm (37 13/16"– 63")  
 Boom arm : 830mm (32 11/16")  
 Weight : 3.2kg (7.1 lbs)  
 Black Finish

**356,00**

## BOOM STAND



### MS205VBK

- Vice-Grip Boom Tilter
- Latch-Lok Sleeve Insert

Height: 965mm – 1,600mm (38" - 63")  
 Boom Arm : 830mm (32 11/16")  
 Weight: 3.26kg (7.1lbs)  
 Black Finish

**516,00**

## LOW PROFILE BOOM STAND



### MS205ST

- Cast Grip Boom Tilter

Height : 430mm – 560mm (17 1/8"– 22 1/16")  
 Boom arm : 510mm (20 1/16")  
 Weight : 2.3kg (5.1 lbs)  
 Chrome Finish

**299,00**

## LOW PROFILE BOOM STAND



### MS205STBK

- Cast Grip Boom Tilter

Height : 430mm – 560mm (17 1/8"– 22 1/16")  
 Boom arm : 510mm (20 1/16")  
 Weight : 2.3kg (5.1 lbs)  
 Black Finish

**299,00**

## STRAIGHT STAND



### MS200BK

Height : 910 - 1550mm (36" - 61")  
 Weight : 2.4kg (5.4lbs)  
 Black Finish

**278,00**

## STRAIGHT STAND WITH ROUND BASE



### MS200DBK

- Cast Round Base with T-Bolt Pipe Fixing Device

Height : 895 - 1510mm (35 1/4" - 59 7/16")  
 Weight : 3.8kg (8.6lbs)  
 Black Finish

**299,00**



## DESK-MOUNTED MICROPHONE BOOM ARM



### MSDA206BK

-Iron-Core Telescoping Boom Arm  
-Cast Grip Boom Tilter  
-Height memory lock  
-Headset hanging hook  
Height: 95 - 515mm (3 3/4" - 20 1/4")  
Boom Arm: 450 - 800mm (17 3/4" - 31 1/2")  
Weight : 1.6kg (3.6lbs)  
Black Finish

**430,00**

## MICROPHONE TELESCOPING BOOM ARM WITH CLAMP



### MSCA734BK

-Iron-Core Telescoping Boom Arm  
-Vice-Grip Boom Tilter  
-Clamp holds pipes with diameters from 15-25.4mm (5/8"-1")  
Boom Arm: 290-455mm (11 7/16"-17 15/16")  
Weight : 0.87kg (1.9lbs)  
Black Finish

**343,00**

## BOOM ARM



### MS736BB

Vice-Grip Boom Tilter with Iron-Core Telescoping Boom Arm

**321,00**

## BOOM ARM



### MS436BB

Cast-Grip Boom Tilter with Iron-Core Telescoping Boom Arm

**278,00**

## TRI-LIFT ADAPTER



### TLA3

An extremely innovative product, the TLA3 Tri-Lift Adaptor is highly useful for setting multiple microphone stands very close together. This adaptor lifts the mic stand's legs up and enables you to place another stand's legs underneath. (3pcs/Set)

**30,00**

## CORD CLIP



### CC5

For 15.9 mm (5/8") diameter tube. (3pcs/Set)

**30,00**

## CORD CLIP



### CC7

For 22.2 mm (7/8") diameter tube. (3pcs/Set)

**30,00**

## DIE-CAST LOCKING THUMB NUT



### DTLN3

For 3/8" connector  
Not only does the thumb nut's larger, sure-grip design allow greater leverage for faster, easier set-up and breakdown, its high quality zinc threads and walls are built to handle pressure for years to come.

**30,00**

## RUBBER FOOT



### 756-RF

TAMA's extra thick rubber foot covers "float" the stand, isolating the microphone from floor vibrations. (for 19.1mm diameter leg)

**30,00**

## GUITAR STAND



### 839

-Adjustable Neck and Body Holder  
-Glide-Tite Grip Joint  
-Die-Cast Tripod Base

**436,00**

# TAMA PERCUSSION

For more than 40 years, TAMA has been inspiring drummers around the world with its unique range of original percussion instruments. Combining the influences of global musical cultures with modern technology, TAMA has given drummers and percussionists of every genre a new lease on creativity with the unique voices these instruments provide.

## GONG BASS DRUM



### MAG20R

20"x14" Starclassic Maple Gong Bass Drum

MEG20R (Exotic Finishes)  
MAG20R (Lacquer Finishes)  
MRG20R (Duracover Finishes)

\*Gong Bass Drums is available in all Starclassic Maple finishes (Exotic/ Lacquer / Duracover Wrap).  
\*\*Gong Bass Drums Shell Hardware is available in Chrome finish only.  
\*\*\*Hardware and tom arms not included.

**5.638,00**

## METALWORKS "EFFECT" STEEL MINI-TYMPMS



### MT68STBK

6"x4" + 8"x4"

Steel Mini-Tympms come with an L-rod (LLT) and multi-clamp (MC66).

**950,00**

## METALWORKS "EFFECT" STEEL MINI-TYMPMS



### MT810STBK

8"x4" + 10"x4"

Steel Mini-Tympms come with an L-rod (LLT) and multi-clamp (MC66).

**994,00**

## JINGLE RING



### TJR7

The Jingle Ring is a slim tambourine that can be mounted on a hi-hat stand or as a separate item. It features 9 pairs of nickel "jingles" that produce a bright, clear, tambourine sound.

**213,00**

## OCTOBAN SET



### 7850N2H

2pc High-pitch set w/HOW29WN stand

**2.339,00**

## OCTOBAN SET



### 7850N2L

2pc Low-pitch set w/HOW29WN stand

**2.817,00**

## OCTOBAN SET



### 7850N4H

4pc High-pitch set w/HOW49WN stand

**4.205,00**

## OCTOBAN SET



### 7850N4L

4pc Low-pitch set w/HOW49WN stand

**5.160,00**

## OCTOBAN



### OCT280N

280mm (11") depth

**820,00**

## OCTOBAN



### OCT301N

301mm (11 3/4") depth

**864,00**

## OCTOBAN



### OCT343N

343mm (13 1/2") depth

**907,00**

## OCTOBAN



### OCT390N

390mm (15 1/2") depth

**950,00**

## OCTOBAN



### OCT443N

443mm (17 1/2") depth

**1.081,00**

## OCTOBAN



### OCT472N

472mm (18 1/2") depth

**1.124,00**

## OCTOBAN



### OCT536N

536mm (21") depth

**1.167,00**

## OCTOBAN



### OCT600N

600mm (23 1/2") depth

**1.254,00**

## OCTOBAN STAND



### HOW29WN

for 2pcs octobans

**820,00**

## OCTOBAN STAND



### HOW49WN

for 4pcs octobans

**907,00**

## OCTOBAN HOLDER FOR DRUM RACK



### OA29

for 2pcs octobans

**343,00**

## OCTOBAN HOLDER FOR DRUM RACK



### OA49

for 4pcs octobans

**386,00**

# PRACTICE TOOLS

Our unique practice tools make your percussive education more enjoyable and productive.

## PRACTICE PAD



### TSP9

This practice pad accurately imitates the natural feel & rebound of an acoustic snare drum. The wooden base and 6mm thick rubber playing surface offer excellent durability. This combination provides easy control and is ideal for hours long practice sessions.

The non-slip base allows the practice pad to rest on a tabletop or snare drum without damaging the surface beneath.

- Unique Playing Surface
- A Natural Feel with the Perfect Bounce

**151,00**

## PRACTICE PAD STAND



### HS40TPN

The HS40TPN practice pad stand can hold pads between 6 and 10 inches in diameter. The EP222 Extension Pipe sold separately.

- Single Braced Legs
- Height Adjustment Range w/o extension pipe: 580mm - 710mm (22 13/16" - 27 15/16")
- w/ extension pipe (EP222): 790mm - 1,065mm (31 1/8" - 41 15/16")

**321,00**

## EXTENSION PIPE FOR PRACTICE PAD STAND



### EP222

The height of the HS40TPN can be easily extended by attaching the EP222 extension pipe between the upper and lower section of unit. No tools are required to install this product.

**108,00**

## MESH HEAD



### MH8T

MH8T (8")	<b>52,00</b>
MH10T (10")	<b>56,00</b>
MH12T (12")	<b>60,00</b>
MH13T (13")	<b>65,00</b>
MH14T (14")	<b>69,00</b>
MH16T (16")	<b>73,00</b>
MH18B (18")	<b>86,00</b>
MH22B (22")	<b>134,00</b>

## SOFT SOUND BEATER



### BSQ10S

Soft Sound Beater provides a significant decrease in volume, but allows you to use your regular bass drum pedal and bass drum head with a natural and accurate feel.

**151,00**

## SOFT SOUND BEATER



### BSQ5S

Soft Sound Beater provides a significant decrease in volume, but allows you to use your regular bass drum pedal and bass drum head with a natural and accurate feel.

- Half size version for twin pedal users

**130,00**

## SOFT SOUND RING



### SSR8

The TAMA Soft Sound Ring is made of 6mm thick foam rubber. This drum accessory reduces the volume of an acoustic drum kit while retaining the natural tone of the shell.

SSR8 (8")	<b>60,00</b>
SSR10 (10")	<b>69,00</b>
SSR12 (12")	<b>86,00</b>
SSR13 (13")	<b>104,00</b>
SSR14 (14")	<b>117,00</b>
SSR16 (16")	<b>130,00</b>

## SOFT SOUND PACKAGE

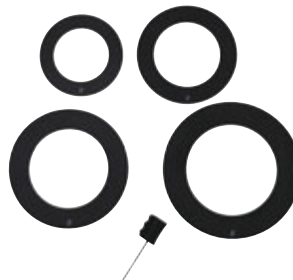

### SSRP52K

22"BD 5pc kit configuration

The Soft Sound package reduces the volume of an acoustic drum kit while retaining the natural tone of the shell. It is designed to maintain the feel of playing an acoustic drum kit; a very important feature when playing in low volume situations.

-10", 12", 14", and 16" Soft Sound Ring  
-Half Soft Sound Beater (BSQ5S)

**412,00**

## SOFT SOUND PACKAGE



### SSRP50

20"BD 5pc kit configuration

The Soft Sound package reduces the volume of an acoustic drum kit while retaining the natural tone of the shell. It is designed to maintain the feel of playing an acoustic drum kit; a very important feature when playing in low volume situations.

-10", 12", and 2pcs of 14" Soft Sound Ring  
-Half Soft Sound Beater (BSQ5S)

**412,00**

## SOFT SOUND PACKAGE

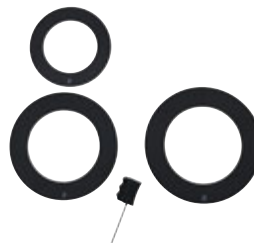

### SSRP48

18"BD 4pc kit configuration

The Soft Sound package reduces the volume of an acoustic drum kit while retaining the natural tone of the shell. It is designed to maintain the feel of playing an acoustic drum kit; a very important feature when playing in low volume situations.

-10", 13", and 14" Soft Sound Ring  
-Half Soft Sound Beater (BSQ5S)

**347,00**

## CYMBAL MUTE



### CM14HH

for 14" hi-hat cymbal

**108,00**

## CYMBAL MUTE



### CM1416

for 14" or 16" cymbal

**56,00**

## CYMBAL MUTE



### CM1820

for 18" or 20" cymbal

**60,00**

## SILENT PRACTICE SET



### SPP518CN

Mesh head for 18" bass drum  
Mesh head for 10" tom tom  
Mesh head for 12" tom tom  
Mesh head for 14" floor tom & snare drum (x2)  
Cymbal mute for 14" hi-hat cymbal  
Cymbal mute for 14" or 16" cymbal  
Cymbal mute for 18" or 20" cymbal

**469,00**

## SILENT PRACTICE SET



### SPP522C

Mesh head for 22" bass drum  
Mesh head for 12" tom tom  
Mesh head for 13" floor tom  
Mesh head for 16" floor tom  
Mesh head for 14" snare drum  
Cymbal mute for 14" hi-hat cymbal  
Cymbal mute for 14" or 16" cymbal  
Cymbal mute for 18" or 20" cymbal

**516,00**

## SILENT PRACTICE SET



### SPP522KC

Mesh head for 22" bass drum  
Mesh head for 10" tom tom  
Mesh head for 12" tom tom  
Mesh head for 16" floor tom  
Mesh head for 14" snare drum  
Cymbal mute for 14" hi-hat cymbal  
Cymbal mute for 14" or 16" cymbal  
Cymbal mute for 18" or 20" cymbal

**516,00**



## SILENT TIPS



### TCP20

TAMA TCP20 is a pair of silicone rubber tips that fit over most drum stick models. These tips make it easy and convenient to practice silently, anytime, anywhere.

**18,00**

## ISO-BASE SOUND REDUCTION PAD SET



### TIBS4

Designed for quiet practice at home, the Iso-Base Sound Reduction Pads offer superb floor vibration isolation. For use with cymbal stands, bass drum pedals, hi-hat stands, and even bass drum spurs, the Iso-Base pads are compact and lightweight for easy set-up, tear down, and portability.

- Including TIBP1 x 1 and TIBL1 x 3

**430,00**

## ISO-BASE SOUND REDUCTION PEDAL PAD



### TIBP1

The Pedal Pad offer bass drum pedal floor vibration isolation during home practice.

**343,00**

## ISO-BASE SOUND REDUCTION LEG PAD



### TIBL1

The Leg Pads offer floor vibration isolation during home practice for cymbal stands, hi-hat stands, and bass drum spurs.

**56,00**

## BAGS

### POWERPAD® BAG -Tom Tom-



### PBT8

PBT8 (8"x7" Tom Tom)  
PBT10 (10"x8" Tom Tom)  
PBT12 (12"x9" Tom Tom)  
PBT13 (13"x10" Tom Tom)

**200,00**

### POWERPAD® BAG -Floor Tom-



### PBF14

PBF14 (14"x14" Floor Tom)  
PBF16 (16"x16" Floor Tom)

**343,00**

### POWERPAD® BAG -Bass Drum-



### PBB18

PBB18 (18"x16" Bass Drum or Floor Tom)  
PBB20 (20"x18" Bass Drum)  
PBB22 (22"x18" Bass Drum)  
PBB24 (24"x18" Bass Drum)

**477,00**

### POWERPAD® BAG -Snare Drum-



### PBS1455

PBS1445 (14"x4.5" Snare Drum)  
PBS1455 (14"x5.5" Snare Drum)  
PBS1465 (14"x6.5" Snare Drum)  
PBS1480 (14"x8" Snare Drum)

**256,00**

## POWERPAD® BAG -Hardware-



### PBH02L

880 (L) x 150 (W) x 200 (H) mm  
(34 5/8" x 5 7/8" x 7 7/8")

-Suitable size for storing about 5 stand

**256,00**

## POWERPAD® BAG -Hardware-



### PBH05

850 (L) x 320 (W) x 220 (H) mm  
(33 1/2" x 12 5/8" x 8 5/8")

-Suitable size for storing about 10 stands  
-Equipped with durable wheels

**838,00**

## POWERPAD® BAG -Cymbal-



### PBC22

The POWERPAD® Series Cymbal Bag is a heavy duty bag designed to carry cymbals up to 22" in diameter. The main compartment contains (3) 22" dividers and the front side pocket contains (3) 15" dividers.

**451,00**

## POWERPAD® BAG -Twin Pedal-



### PBP200

The PBP200 can accommodate both single and double pedals.

450 (L) x 300 (W) x 200 (H) mm  
(17 3/4" x 11 7/8" x 7 7/8")

**265,00**

## POWERPAD® BAG -Single Pedal-



### PBP100

The POWERPAD® Series bag for single pedal.

220 (D) x 190 (W) x 400 (H) mm  
(8 5/8" x 7 1/2" x 15 3/4")

**130,00**

## POWERPAD® BAG -Drum Throne-



### PBTH15

-Carries any TAMA drum throne  
-Carries 14" snare drum and snare drum stand  
-Shoulder strap and handle for easy transportation

**330,00**

## POWERPAD® BAG -Stick & Mallet-



### PBS50

Stores about 24 pairs of sticks & mallets

-Large front pocket for sheet music  
-Built-in hooks easily attach to floor tom  
-Padded Shoulder strap  
-Convenient inner pockets  
-Height: 500mm  
-Open Width: 580mm

**256,00**

## POWERPAD® BAG -Stick-



### PBS24

Stores about 12 pairs of sticks & mallets

**161,00**

## POWERPAD® DESIGNER BAG -Drum Set-



### TDSS52KBK

Black  
22"x18" Bass Drum  
10"x8" Tom Tom  
12"x9" Tom Tom  
16"x16" Floor Tom  
14"x6.5" Snare Drum

-10mm thick inner cushions  
-Ergonomic rubber handle  
-A comfortable padded shoulder strap (for the snare drum bag)

**1.037,00**

## POWERPAD® DESIGNER BAG -Drum Set-



### TDSS52KBE

Beige  
22"x18" Bass Drum  
10"x8" Tom Tom  
12"x9" Tom Tom  
16"x16" Floor Tom  
14"x6.5" Snare Drum

-10mm thick inner cushions  
-Ergonomic rubber handle  
-A comfortable padded shoulder strap (for the snare drum bag)

**1.037,00**

## POWERPAD® DESIGNER BAG -Drum Set-



### TDSS52KMG

Moss Green  
22"x18" Bass Drum  
10"x8" Tom Tom  
12"x9" Tom Tom  
16"x16" Floor Tom  
14"x6.5" Snare Drum

-10mm thick inner cushions  
-Ergonomic rubber handle  
-A comfortable padded shoulder strap (for the snare drum bag)

**1.037,00**

## POWERPAD® DESIGNER BAG -Drum Set-



### TDSS52KNB

Navy Blue  
22"x18" Bass Drum  
10"x8" Tom Tom  
12"x9" Tom Tom  
16"x16" Floor Tom  
14"x6.5" Snare Drum

-10mm thick inner cushions  
-Ergonomic rubber handle  
-A comfortable padded shoulder strap (for the snare drum bag)

**1.037,00**

## POWERPAD® DESIGNER BAG -Drum Set-



### TDSS52KWR

Wine Red  
22"x18" Bass Drum  
10"x8" Tom Tom  
12"x9" Tom Tom  
16"x16" Floor Tom  
14"x6.5" Snare Drum

-10mm thick inner cushions  
-Ergonomic rubber handle  
-A comfortable padded shoulder strap (for the snare drum bag)

**1.037,00**

## POWERPAD® DESIGNER BAG -8" Tom Tom-



### TSBT8BK

Black  
8"x7" Tom Tom

-10mm thick inner cushions  
-Ergonomic rubber handle

**108,00**

## POWERPAD® DESIGNER BAG -8" Tom Tom-



### TSBT8BE

Beige  
8"x7" Tom Tom

-10mm thick inner cushions  
-Ergonomic rubber handle

**108,00**

## POWERPAD® DESIGNER BAG -8" Tom Tom-



### TSBT8MG

Moss Green  
8"x7" Tom Tom

-10mm thick inner cushions  
-Ergonomic rubber handle

**108,00**

## POWERPAD® DESIGNER BAG -8" Tom Tom-



### TSBT8NB

Navy Blue  
8"x7" Tom Tom

-10mm thick inner cushions  
-Ergonomic rubber handle

**108,00**

## POWERPAD® DESIGNER BAG -8" Tom Tom-



### TSBT8WR

Wine Red  
8"x7" Tom Tom

-10mm thick inner cushions  
-Ergonomic rubber handle

**108,00**

## POWERPAD® DESIGNER BAG -14" Floor Tom-



### TSBF14BK

Black  
14"x14" Tom Tom

-10mm thick inner cushions  
-Ergonomic rubber handle

**164,00**

## POWERPAD® DESIGNER BAG -14" Floor Tom-



### TSBF14BE

Beige  
14"x14" Tom Tom

-10mm thick inner cushions  
-Ergonomic rubber handle

**164,00**

**POWERPAD® DESIGNER BAG -14" Floor Tom-**



**TSBF14MG**

Moss Green  
14"x14" Tom Tom

- 10mm thick inner cushions
- Ergonomic rubber handle

**164,00**

**POWERPAD® DESIGNER BAG -14" Floor Tom-**



**TSBF14NB**

Navy Blue  
14"x14" Tom Tom

- 10mm thick inner cushions
- Ergonomic rubber handle

**164,00**

**POWERPAD® DESIGNER BAG -14" Floor Tom-**



**TSBF14WR**

Wine Red  
14"x14" Tom Tom

- 10mm thick inner cushions
- Ergonomic rubber handle

**164,00**

**POWERPAD® DESIGNER BAG -Snare Drum-**



**TSDB1465BK**

Black  
14"x6.5" Snare Drum

- Convertible Backpack Straps
- 20mm thick semi-hard cushion
- Backpack Straps and ergonomic rubber handle

**290,00**

**POWERPAD® DESIGNER BAG -Snare Drum-**



**TSDB1465BE**

Beige  
14"x6.5" Snare Drum

- Convertible Backpack Straps
- 20mm thick semi-hard cushion
- Backpack Straps and ergonomic rubber handle

**290,00**

**POWERPAD® DESIGNER BAG -Snare Drum-**



**TSDB1465MG**

Moss Green  
14"x6.5" Snare Drum

- Convertible Backpack Straps
- 20mm thick semi-hard cushion
- Backpack Straps and ergonomic rubber handle

**290,00**

**POWERPAD® DESIGNER BAG -Snare Drum-**



**TSDB1465NB**

Navy Blue  
14"x6.5" Snare Drum

- Convertible Backpack Straps
- 20mm thick semi-hard cushion
- Backpack Straps and ergonomic rubber handle

**290,00**

**POWERPAD® DESIGNER BAG -Snare Drum-**



**TSDB1465WR**

Wine Red  
14"x6.5" Snare Drum

- Convertible Backpack Straps
- 20mm thick semi-hard cushion
- Backpack Straps and ergonomic rubber handle

**290,00**

**POWERPAD® DESIGNER BAG -Hardware-**



**THB02LBK**

Black  
880 (L) x 150 (W) x 200 (H) mm  
(34 5/8" x 5 7/8" x 7 7/8")

- Suitable size for storing about 4 stands

**212,00**

**POWERPAD® DESIGNER BAG -Hardware-**



**THB02LBE**

Beige  
880 (L) x 150 (W) x 200 (H) mm  
(34 5/8" x 5 7/8" x 7 7/8")

- Suitable size for storing about 4 stands

**212,00**

## POWERPAD® DESIGNER BAG -Hardware-



### THB02LMG

Moss Green

880 (L) x 150 (W) x 200 (H) mm  
(34 5/8" x 5 7/8" x 7 7/8")

-Suitable size for storing about 4 stands

**212,00**

## POWERPAD® DESIGNER BAG -Hardware-



### THB02LNB

Navy Blue

880 (L) x 150 (W) x 200 (H) mm  
(34 5/8" x 5 7/8" x 7 7/8")

-Suitable size for storing about 4 stands

**212,00**

## POWERPAD® DESIGNER BAG -Hardware-



### THB02LWR

Wine Red

880 (L) x 150 (W) x 200 (H) mm  
(34 5/8" x 5 7/8" x 7 7/8")

-Suitable size for storing about 4 stands

**212,00**

## POWERPAD® DESIGNER BAG -Hardware-



### THB04XLBK

Black

880 (L) x 180 (W) x 250 (H) mm  
(34 5/8" x 7 1/16" x 9 13/16")

-Suitable size for storing HV5WN hardware kit  
without drum pedal  
(2-HC83BW, HS80W, HH605)

**260,00**

## POWERPAD® DESIGNER BAG -Cymbal-



### TCB22BK

Black

up to 22" Cymbal + 15" Cymbal (front side pocket)

-20mm thick semi-hard cushion  
-Padded shoulder Straps and handle  
-22" compartment dividers (3pcs) and 15"  
compartment dividers (3pcs) included

**381,00**

## POWERPAD® DESIGNER BAG -Cymbal-



### TCB22BE

Beige

up to 22" Cymbal + 15" Cymbal (front side pocket)

-20mm thick semi-hard cushion  
-Padded shoulder Straps and handle  
-22" compartment dividers (3pcs) and 15"  
compartment dividers (3pcs) included

**381,00**

## POWERPAD® DESIGNER BAG -Cymbal-



### TCB22MG

Moss Green

up to 22" Cymbal + 15" Cymbal (front side pocket)

-20mm thick semi-hard cushion  
-Padded shoulder Straps and handle  
-22" compartment dividers (3pcs) and 15"  
compartment dividers (3pcs) included

**381,00**

## POWERPAD® DESIGNER BAG -Cymbal-



### TCB22NB

Navy Blue

up to 22" Cymbal + 15" Cymbal (front side pocket)

-20mm thick semi-hard cushion  
-Padded shoulder Straps and handle  
-22" compartment dividers (3pcs) and 15"  
compartment dividers (3pcs) included

**381,00**

## POWERPAD® DESIGNER BAG -Cymbal-



### TCB22WR

Wine Red

up to 22" Cymbal + 15" Cymbal (front side pocket)

-20mm thick semi-hard cushion  
-Padded shoulder Straps and handle  
-22" compartment dividers (3pcs) and 15"  
compartment dividers (3pcs) included

**381,00**

## POWERPAD® DESIGNER BAG -Cajon-



### TCB01BK

Black

330 (L) x 310 (W) x 520 (H) mm  
(13" x 12 1/4" x 20 1/2")

-Backpack straps

**338,00**



## POWERPAD® DESIGNER BAG -Cajon-



### TCB01BE

Beige

330 (L) x 310 (W) x 520 (H) mm  
(13" x 12 1/4" x 20 1/2")

-Backpack straps

**338,00**

## POWERPAD® DESIGNER BAG -Cajon-



### TCB01MG

Moss Green

330 (L) x 310 (W) x 520 (H) mm  
(13" x 12 1/4" x 20 1/2")

-Backpack straps

**338,00**

## POWERPAD® DESIGNER BAG -Cajon-



### TCB01NB

Navy Blue

330 (L) x 310 (W) x 520 (H) mm  
(13" x 12 1/4" x 20 1/2")

-Backpack straps

**338,00**

## POWERPAD® DESIGNER BAG -Cajon-



### TCB01WR

Wine Red

330 (L) x 310 (W) x 520 (H) mm  
(13" x 12 1/4" x 20 1/2")

-Backpack straps

**338,00**

## POWERPAD® DESIGNER BAG -Twin Pedal-



### TPB200BK

Black

450 (L) x 200 (W) x 300 (H) mm  
(17 3/4" x 7 7/8" x 11 3/4")

-Accommodate both single and double pedals  
-Removable storage case for using as single pedal case

**303,00**

## POWERPAD® DESIGNER BAG -Twin Pedal-



### TPB200BE

Beige

450 (L) x 200 (W) x 300 (H) mm  
(17 3/4" x 7 7/8" x 11 3/4")

-Accommodate both single and double pedals  
-Removable storage case for using as single pedal case

**303,00**

## POWERPAD® DESIGNER BAG -Twin Pedal-



### TPB200MG

Moss Green

450 (L) x 200 (W) x 300 (H) mm  
(17 3/4" x 7 7/8" x 11 3/4")

-Accommodate both single and double pedals  
-Removable storage case for using as single pedal case

**303,00**

## POWERPAD® DESIGNER BAG -Twin Pedal-



### TPB200NB

Navy Blue

450 (L) x 200 (W) x 300 (H) mm  
(17 3/4" x 7 7/8" x 11 3/4")

-Accommodate both single and double pedals  
-Removable storage case for using as single pedal case

**303,00**

## POWERPAD® DESIGNER BAG -Twin Pedal-



### TPB200WR

Wine Red

450 (L) x 200 (W) x 300 (H) mm  
(17 3/4" x 7 7/8" x 11 3/4")

-Accommodate both single and double pedals  
-Removable storage case for using as single pedal case

**303,00**

## POWERPAD® DESIGNER BAG -Stick-



### TSB24BK

Black

-Main pockets for 12 pairs of sticks, and side pockets for accessories  
-Built-in hooks easily attach to floor tom  
-Shoulder strap for portability  
-Convenient inner pockets  
-Size: 460mm x 180mm  
-Side Pocket: 260mm x 160mm

**134,00**

### POWERPAD® DESIGNER BAG -Stick-



#### TSB24BE

Beige

- Main pockets for 12 pairs of sticks, and side pockets for accessories
- Built-in hooks easily attach to floor tom
- Shoulder strap for portability
- Convenient inner pockets
- Size: 460mm x 180mm
- Side Pocket: 260mm x 160mm

**134,00**

### POWERPAD® DESIGNER BAG -Stick-



#### TSB24MG

Moss Green

- Main pockets for 12 pairs of sticks, and side pockets for accessories
- Built-in hooks easily attach to floor tom
- Shoulder strap for portability
- Convenient inner pockets
- Size: 460mm x 180mm
- Side Pocket: 260mm x 160mm

**134,00**

### POWERPAD® DESIGNER BAG -Stick-



#### TSB24NB

Navy Blue

- Main pockets for 12 pairs of sticks, and side pockets for accessories
- Built-in hooks easily attach to floor tom
- Shoulder strap for portability
- Convenient inner pockets
- Size: 460mm x 180mm
- Side Pocket: 260mm x 160mm

**134,00**

### POWERPAD® DESIGNER BAG -Stick-



#### TSB24WR

Wine Red

- Main pockets for 12 pairs of sticks, and side pockets for accessories
- Built-in hooks easily attach to floor tom
- Shoulder strap for portability
- Convenient inner pockets
- Size: 460mm x 180mm
- Side Pocket: 260mm x 160mm

**134,00**

### POWERPAD® DESIGNER BAG -Stick-



#### TSB12BK

Black

Stores about 6 pairs of sticks

- Top of the bag open to take out stick easily
- Elastic band easily attach to floor tom
- Convenient inner pockets

**82,00**

### POWERPAD® DESIGNER BAG -Stick-



#### TSB12BE

Beige

Stores about 6 pairs of sticks

- Top of the bag open to take out stick easily
- Elastic band easily attach to floor tom
- Convenient inner pockets

**82,00**

### POWERPAD® DESIGNER BAG -Stick-



#### TSB12MG

Moss Green

Stores about 6 pairs of sticks

- Top of the bag open to take out stick easily
- Elastic band easily attach to floor tom
- Convenient inner pockets

**82,00**

### POWERPAD® DESIGNER BAG -Stick-



#### TSB12NB

Navy Blue

Stores about 6 pairs of sticks

- Top of the bag open to take out stick easily
- Elastic band easily attach to floor tom
- Convenient inner pockets

**82,00**

### POWERPAD® DESIGNER BAG -Stick-



#### TSB12WR

Wine Red

Stores about 6 pairs of sticks

- Top of the bag open to take out stick easily
- Elastic band easily attach to floor tom
- Convenient inner pockets

**82,00**

### POWERPAD® DESIGNER BAG -Stick-



#### TSB12DBK

Black Denim

Stores about 6 pairs of sticks

- Top of the bag open to take out stick easily
- Elastic band easily attach to floor tom
- Convenient inner pockets

**82,00**

## POWERPAD® DESIGNER BAG -Stick-



### TSB12DBL

Blue Denim  
Stores about 6 pairs of sticks

- Top of the bag open to take out stick easily
- Elastic band easily attach to floor tom
- Convenient inner pockets

**82,00**

## STANDARD SERIES DRUM BAG SET



### DSS52K

22"x18"BD  
10"x8"TT  
12"x9"TT  
16"x16"FT  
14"x6.5"SD

- 600 denier high density water resister surface
- Water resistant nylon with 10mm thick cushion
- Ergonomic rubber handles

**1.055,00**

## STANDARD SERIES DRUM BAG SET



### DSS50S

20"x18"BD  
10"x8"TT  
12"x9"TT  
14"x14"FT  
14"x6.5"SD

- 600 denier high density water resister surface
- Water resistant nylon with 10mm thick cushion
- Ergonomic rubber handles

**1.055,00**

## STANDARD SERIES DRUM BAG SET



### DSS62S

22"x18"BD  
10"x8"TT  
12"x9"TT  
14"x14"FT  
16"x16"FT  
14"x6.5"SD

- 600 denier high density water resister surface
- Water resistant nylon with 10mm thick cushion
- Ergonomic rubber handles

**1.211,00**

## STANDARD SERIES DRUM BAG SET



### DSS48LJ

(for Club-JAM kit)  
18"x12" BD  
10"x8" TT  
14"x7" FT & 13"x5" SD (1bag)

- 600 denier high density water resister surface
- Water resistant nylon with 10mm thick cushion
- Ergonomic rubber handles

**551,00**

## STANDARD SERIES DRUM BAG SET



### DSS28LJ

(for Club-JAM MINI kit)  
18"x12" BD  
12"x5" SD

- 600 denier high density water resister surface
- Water resistant nylon with 10mm thick cushion
- Ergonomic rubber handles

**399,00**

## STANDARD SERIES DRUM BAG SET



### DSS36LJ

(for Club-JAM Suitcase kit)  
16"x15" BD  
10"x7" TT  
12"x6" FT

- 600 denier high density water resister surface
- Water resistant nylon with 10mm thick cushion
- Ergonomic rubber handles

**482,00**

## STANDARD SERIES DRUM BAG SET



### DSS44LJ

(for Club-JAM Flyer kit)  
14"x10" BD  
10"x9" FT & 8"x6" TT (1bag)  
10"x5" SD bag

- 600 denier high density water resister surface
- Water resistant nylon with 10mm thick cushion
- Ergonomic rubber handles

**551,00**

## STANDARD SERIES DRUM BAG SET



### DSS48LJP

(for Club-JAM Pancake kit)  
18"x4" BD  
10"x3.5" TT  
13"x3.5" FT  
12"x4" SD

- 600 denier high density water resister surface
- Water resistant nylon with 10mm thick cushion
- Ergonomic rubber handles

**503,00**

## STANDARD SERIES DRUM BAG SET



### DSS48S

18"x14" BD  
12"x9" TT  
14"x14" FT  
14"x6.5" SD

- 600 denier high density water resister surface
- Water resistant nylon with 10mm thick cushion
- Ergonomic rubber handles

**911,00**

## STANDARD SERIES DRUM BAG SET



### DSS72S

22"x18" BD  
8"x7" TT  
10"x8" TT  
12"x9" TT  
14"x14" FT  
16"x16" FT  
14"x6.5" SD

- 600 denier high density water resister surface
- Water resistant nylon with 10mm thick cushion
- Ergonomic rubber handles

**1.311,00**

## STANDARD SERIES SNARE BAG



### SBS14

14"x6.5" Snare Drum

- 600 denier high density water resister surface
- Water resistant nylon with 10mm thick cushion
- Ergonomic rubber handles
- Carrying strap with shoulder pads

**152,00**

## STANDARD SERIES HARDWARE BAG



### SBH01

(for Compact / Lightweight Hardware)  
670 (L) x180 (W) x190 (H) mm

- 600 denier high density water resister surface
- Water resistant nylon with 10mm thick cushion
- Carrying strap with shoulder pads

**200,00**

## STANDARD SERIES MICROPHONE STAND BAG



### SBM01

Stores up to 6 pcs of Microphone Stands or 2pcs of Speaker Stands  
1200 (L) x 220 (W) x 200 (H) mm

- 600 denier high density water resister surface
- Water resistant nylon with 10mm thick cushion
- Carrying strap with shoulder pad

**304,00**

# ACCESSORIES

We offer many unique accessories to enhance your playing, set up, and tone of the drums.

## ACCESSORY TRAY



### TAT10

- Tray size (inside dimension): 235mm x 254mm (9 1/4" x 10")
- Drink holder: up to diameter 90mm (3 1/2")
- Includes MC61 FastClamp for connecting stands with pipes from 15.9mm to 28.6mm in diameter.
- Includes 2- S-Hooks for hanging bags
- Rims can hold up to 16mm (0.63") diameter drum sticks
- Mounted 5/8" nut for straight mic stand on bottom of the tray
- Weight capacity: 2.5kg (5.5lbs)

**299,00**

## DRUM STICK HOLDER



### STH10

The STH10 Stick Holder is designed to hold spare sticks and can be attached to hardware anywhere on the drum kit.

- Size: 280mm(L) x 60mm(W) x 90mm(H) (11 1/32" x 2 11/32" x 3 17/32")
- Storing 2 pairs of drumsticks
- The attachment for connecting stands with pipes from 15.9mm to 28.6mm in diameter.

**52,00**

## RHYTHM WATCH



### RW200

Tempo Range: 30-250 BPM  
Tempo, Beat & Sound Memory: 30 Songs  
Beats: 0-9  
Display: LCD with BACK LIGHT  
Size: 127 x 35 x 150mm (5" x 1.4" x 6")  
Weight: 285g including battery  
Power Supply: 9V Battery (S-006P) or DC9V 200mA adapter

**430,00**

## RHYTHM WATCH MINI



### RW30

Tempo Range: 30-250 BPM  
Beats: 0-9  
Display: LCD display with BACK LIGHT  
Size: 61 x 25 x 118mm (2 1/2" x 1" x 4 5/8")  
Weight: 90g including battery  
Power Supply: 2 x AAA Batteries (3V)

**160,00**



## RHYTHM WATCH HOLDER



### RWH10

for RW200

**82,00**

## TENSION WATCH



### TW200

The TW200 TAMA Tension Watch is very compact and is equipped with an easy-to-read dial. It comes with a detachable nylon bumper to ensure consistent measuring distance from the hoop, resulting in an evenly tensioned drum for the best sound.

**560,00**

## TENSION WATCH



### TW100

The TW100 measures actual head tension and features an easy-to-read meter, so you can record the numbers and duplicate your best tuning time after time. You can also use the sample tunings suggested in the directions.

**516,00**

## DRUMMER'S GLOVE



### TDG10BK

Drummer's Glove with featuring extra soft and durable synthetic leather which prevents any slipping while playing even with wet condition caused by sweating.

Black  
TDG10BKM (Medium)  
TDG10BK (Large)  
TDG10BKXL (Extra Large)

**151,00**

## GRIP WRAP



### TGW10BK

MADE IN JAPAN

(2prs / set)

TAMA's Grip Wrap is designed to provide the player with a comfortable, non-slip surface for their drumsticks.

-Non-Slip Surface  
-Soft and Comfortable Feel  
-Highly Durable Material Made in Japan

**43,00**

## WOOD HOOP PROTECTOR



### WHP2

(2pcs / set)

Special adhesive pieces protect your wood hoop from being scratched by preventing the bass drum pedal from twisting or slipping.

**21,00**

## MULTI TOOL



### TMT9

Quick access multi tool for drums

-Hex Wrench 5.0mm/4.0mm/3.0mm/2.5mm/  
2.0mm, Keychain Link, Hex Nut Driver, Phillips  
Screwdriver, Drum Keys (x2)

**91,00**

## DRUM RUG -TAMA Logo Pattern-



### TDR-TL

2,000mm x 1,800mm  
(78 3/4" x 70 7/8")

-Non-slip design helps keep drums & hardware in place  
-Extra-large size accommodates most drum setups  
-Hook and loop fasteners for easy transport

**712,00**

## DRUM RUG -TAMA Logo Pattern / Small-



### TDRS-TL

1,680mm x 1,330mm  
(66 1/8" x 52 3/8")

-Non-slip design helps keep drums & hardware in place  
-Fits to accommodate compact drum set  
-Hook and loop fasteners for easy transport

**430,00**

## DRUM RUG -Oriental Pattern-



### TDR-OR

2,000mm x 1,800mm  
(78 3/4" x 70 7/8")

-Non-slip design helps keep drums & hardware in place  
-Extra-large size accommodates most drum setups  
-Hook and loop fasteners for easy transport

**712,00**



## DRUM RUG -Southwestern Pattern-



### TDR-SW

2,000mm x 1,800mm  
(78 3/4" x 70 7/8")

- Non-slip design helps keep drums & hardware in place
- Extra-large size accommodates most drum setups
- Hook and loop fasteners for easy transport

**712,00**

## DRUM RUG -Paisley Pattern-



### TDR-PA

2,000mm x 1,800mm  
(78 3/4" x 70 7/8")

- Non-slip design helps keep drums & hardware in place
- Extra-large size accommodates most drum setups
- Hook and loop fasteners for easy transport

**712,00**

## REMO® FIBERSKYN POWERSTROKE 3 DIPLOMAT



### RFxxBMST

(TAMA Logo)

RF18BMST (18")	<b>256,00</b>
RF20BMST (20")	<b>277,00</b>
RF22BMST (22")	<b>303,00</b>
RF24BMST (24")	<b>329,00</b>

## WHITE COATED HEADS



### CTxxBMOT

(TAMA & Starclassic Logo)

CT18BMOT (18")	<b>164,00</b>
CT20BMOT (20")	<b>191,00</b>
CT22BMOT (22")	<b>199,00</b>
CT24BMOT (24")	<b>221,00</b>
CT26BMOT (26")	<b>247,00</b>

## FIBER LAMINATED HEADS



### FBxxBMFS

(TAMA & Starclassic Logo)

FB20BMFS (20")	<b>204,00</b>
FB22BMFS (22")	<b>217,00</b>
FB24BMFS (24")	<b>239,00</b>

## BLACK HEADS



### BKxxBMTT

(TAMA & Starclassic Logo)

BK20BMTT (20")	<b>204,00</b>
BK22BMTT (22")	<b>217,00</b>
BK24BMTT (24")	<b>239,00</b>

## SMOOTH WHITE HEADS



### SWxxBMTT

(TAMA & Starclassic Logo)

SW20BMTT (20")	<b>204,00</b>
SW22BMTT (22")	<b>217,00</b>
SW24BMTT (24")	<b>239,00</b>

## FIBER LAMINATED HEADS -BLACK-



### BKxxBMFH

(TAMA Logo for Superstar Hyper-Drive)

BK22BMFH (22")	<b>217,00</b>
BK24BMFH (24")	<b>239,00</b>

## WHITE COATED HEADS -TAMA LOGO-



### CTxxBMSV

(TAMA Logo)

CT18BMSV (18")	<b>178,00</b>
CT20BMSV (20")	<b>204,00</b>
CT22BMSV (22")	<b>217,00</b>

## BLACK HEADS -TAMA LOGO-



### BKxxBMWS

(TAMA Logo)

BK20BMWS (20")	<b>204,00</b>
BK22BMWS (22")	<b>217,00</b>
BK24BMWS (24")	<b>239,00</b>

## DRUM KEY



### TDK10

Chrome

**25,00**

## DRUM KEY



### TDK10BN

Black Nickel

**29,00**

## DRUM KEY



### TDK05

**15,00**

## TENSION LOCK



### TTL10

(10pcs/set)

The Tension Lock prevents tension bolts from loosening while playing by simply set it on the tension bolt head. You can tune the drum without having to detach the Tension Lock, thanks to an elastic O-ring around its hole.

**49,00**

## DIE-CAST HOOPS



### MDH14

TAMA's die-cast hoops deliver an incredibly sharp, solid rim shot that cannot be found in any other hoop.

MDH14-8 (14" 8 hole batter side) **430,00**

MDH14S-8 (14" 8 hole snare side) **430,00**

MDH14-10 (14" 10 hole batter side) **430,00**

MDH14S-10 (14" 10 hole snare side) **430,00**

## 2.3mm BRASS MIGHTY HOOPS



### MFB14

Brass Mighty Hoop provides a warm and open sound with mild attack and long sustain.

MFB14-10N (14" 10 hole batter side) **586,00**

MFB14S-10N (14" 10 hole snare side) **586,00**

## 2.3mm STEEL MIGHTY HOOPS



### MFM14

Steel Mighty Hoop provides a bright and open sound.

MFM14-8 (14" 8 hole batter side) **260,00**

MFM14S-8 (14" 8 hole snare side) **260,00**

MFM14-10 (14" 10 hole batter side) **260,00**

MFM14S-10 (14" 10 hole snare side) **260,00**

## 3.0mm ULTIMATE STEEL MIGHTY HOOPS



### MUS14

3.0mm thick Ultimate Steel Mighty Hoop provides extra power and volume.

MUS1410 (14" 10 hole batter side) **299,00**

MUS14S10 (14" 10 hole snare side) **299,00**

## 2.3mm SOUND ARC HOOPS



### MSH14

Steel Sound Arc Hoop enhances the natural tone of the snare drum and offers sensitivity, precise tuning, and control.

MSH1410 (14" 10 hole batter side) **213,00**

MSH14S10 (14" 10 hole snare side) **213,00**

## 2.3mm BRASS SOUND ARC HOOPS



### MSB14

Brass Sound Arc Hoop provides an open sound with rich harmonic overtones, made of brass with an inward curved shape.

MSB148D (14" 8 hole batter side) **430,00**

MSB14S8D (14" 8 hole snare side) **430,00**

## CUSTOMIZED BRASS MIGHTY HOOPS



### MSP14

Customized Brass Mighty Hoop provides a sharper and brighter attack with rich harmonic overtones, made of brass with a slightly shaved down edge.

MSP14-8 (14" 8 hole batter side) **516,00**

MSP14S-8 (14" 8 hole snare side) **516,00**

## MAPLE WOOD HOOPS



### WMH14

Wood Hoop provides a warm, woody sound with soft attack. Can be mounted on a standard 14" snare drum stand.

WMH1408B (14" 8 hole batter side) **607,00**

WMH1408S (14" 8 hole snare side) **607,00**

WMH1410B (14" 10 hole batter side) **516,00**

WMH1410S (14" 10 hole snare side) **516,00**

## SUPER SENSITIVE HI-CARBON SNARE WIRES

### MS20RL

Super Sensitive Hi-Carbon Snare Wire fits more closely to the snare side head, providing greater sensitivity and brighter, crisper sound.



MS20RL13C (13" 20 strands Hi-Carbon Steel) **108,00**

MS20RL14C (14" 20 strands Hi-Carbon Steel) **108,00**

## SUPER SENSITIVE HI-CARBON SNARE WIRE FOR CONCERT

### MS20L14C8

A thin brass plate and softer hi-carbon coils respond to even the softest touch on the edge of the batter head.



**108,00**

## STAINLESS STEEL STRAIGHT SNARE WIRE

### MS20M14ST

20 strands steel straight wire for concert. Extra short sustain, dark and crisp.



MS20M14ST (14" 20 strands Steel)

**221,00**

## STARCLASSIC SNARE WIRES -CARBON STEEL-

### MS20SNxxS

MS20SN10S (10" 20 strands Carbon Steel) **69,00**

MS20SN12S (12" 20 strands Carbon Steel) **69,00**

MS20SN13S (13" 20 strands Carbon Steel) **69,00**

MS20SN14S (14" 20 strands Carbon Steel) **69,00**



## STARCLASSIC SNARE WIRES -BELL BRASS-

### MS20SN14B

The MS20SN14B features bell brass strands for greater sensitivity.



MS20SN14B (14" 20 strands Bell Brass)

**108,00**

## STARCLASSIC SNARE WIRES -HI-CARBON STEEL-

### MS20SNxxC

MS20SN13C (13" 20 strands Hi-Carbon Steel) **108,00**

MS20SN14C (14" 20 strands Hi-Carbon Steel) **108,00**



## REGULAR SNARE WIRES -CARBON STEEL-

### MS12R14S

(14" 12-strand Carbon Steel)

**56,00**



## REGULAR SNARE WIRES -CARBON STEEL-

### MS20R14S

(14" 20-strand Carbon Steel)

**60,00**



## REGULAR SNARE WIRES -CARBON STEEL-

### MS30R14S

(14" 30-strand Carbon Steel)

**99,00**



## REGULAR SNARE WIRES -CARBON STEEL-

### MS42R14S

(14" 42-strand Carbon Steel)

**104,00**



## REGULAR SNARE WIRES -HI-CARBON STEEL-

### MS42R14C

(14" 42-strand Hi-Carbon Steel)

**117,00**



## HOLD TIGHT™ WASHERS

### SRW620P

(20pcs/set)

The rubber rings inside of the cup-shaped stainless steel washers absorb impact vibrations and keep the hoop and tension bolts in constant contact to prevent from loosening of tension.

**73,00**



## PLASTIC WASHERS

### PW620

(20pcs/set)

2.5mm thick nylon washers decrease noise and make tuning easier and more stable.

**26,00**



## METAL WASHERS

### MW620

(20pcs/set)

Standard metal tension bolt washers.

**26,00**



## SNARE WIRE STRAPS

### MST20

(2pcs/set)

These flexible yet durable 15mm wide nylon snare wire straps are featured on most of TAMA snare drums.

**21,00**



## SNARE WIRE STRINGS

### SPC50P4

(2prs/pack)

The amazingly durable and flexible snare wire string is made of Dupont Kevlar® cable wrapped in polyester fiber for an even higher tensile strength than steel wire. (Kevlar® is a registered trademark of Dupont® Corporation.)

**32,00**



## DYNA BEATER

### BDY30FB

Featuring black felt and a slightly tapered shape, this traditional style beater provides impact to the bass drum head surface evenly to maximize clear, dynamic articulation.

**147,00**



## POWER-STRIKE COBRA BEATER

### CB900PS

Felt

**130,00**



### ACCU-STRIKE COBRA BEATER



**CB900AS**

Rubber

**130,00**

### COBRA BEATER -Felt-



**CB90F**

Felt

**121,00**

### COBRA BEATER -Rubber-



**CB90R**

Rubber

**121,00**

### COBRA BEATER -Wood-



**CB90W**

Wood

**121,00**

### POWER-STRIKE COBRA BEATER HEAD



**CB900PSH**

Felt

**108,00**

### ACCU-STRIKE COBRA BEATER HEAD



**CB900ASH**

Rubber

**108,00**

### COBRA BEATER HEAD -Felt-



**CB90FH**

Felt

**86,00**

### COBRA BEATER HEAD -Rubber-



**CB90RH**

Rubber

**86,00**

### COBRA BEATER HEAD -Wood-



**CB90WH**

Wood

**86,00**

### DUAL SIDED BEATER -Felt-



**DS30**

Felt

**108,00**



### DUAL SIDED BEATER -Felt-



**DS30G**

Felt

**108,00**

### DUAL SIDED BEATER -Rubber-



**DS30R**

Rubber

**108,00**

### THE CLASSIC BEATER -Felt-



**CLB30F**

Felt

**99,00**

### TRADITIONAL BEATER -Felt-



**TTB30F**

Felt

**121,00**

### TRADITIONAL BEATER -Wood-



**TTB30W**

Wood

**121,00**

### TOE STOPPER



**HP900-81**

**21,00**

### BEATER BALANCER



**BC7**

**21,00**

### TIGHT LOCK



**TLK5**

**21,00**

### SPRING FOR SPEED COBRA



**HP910-7S**

**21,00**

### SPRING -Regular-



**HP900-7R**

**21,00**

## SPRING -Heavy-



**HP900-7H**

**21,00**

## COBRA COIL



**CC900S**

The Cobra Coil is a steel spring which assists in the return of the footboard to its original position. It be adjusted to different positions, forward or backward, on the base plate.

**130,00**

## DRUM HAMMER



**DH7**

**43,00**

## TWIN PEDAL ATTACHMENT



**TPA90**

Specially designed attachment to connect Speed Cobra and Iron Cobra 900 series pedals with Speed Cobra and Iron Cobra 900 series Hi-hat stands.

**65,00**

## DYNA-SYNC PEDAL CASE -SINGLE-



**PCDS1**

PCDS1 (for Dyna-Sync Single Pedal)

**316,00**

## DYNA-SYNC PEDAL CASE -TWIN-



**PCDS1TW**

PCDS1TW (for Dyna-Sync Twin Pedal)

**434,00**

## IRON COBRA PEDAL CASE -SINGLE-



**PC900S**

PC900S (for Iron Cobra Single Pedal)

**316,00**

## IRON COBRA PEDAL CASE -TWIN-



**PC900TW**

PC900TW (for Iron Cobra Twin Pedal)

**434,00**

## SPEED COBRA PEDAL CASE -SINGLE-



**PC910S**

PC910S (for Speed Cobra Single Pedal)

**316,00**

## SPEED COBRA PEDAL CASE -TWIN-



**PC910TW**

PC910TW (for Speed Cobra Twin Pedal)

**434,00**

### 1ST CHAIR ROUND RIDER XL SEAT -Cloth Top-



#### HTS8BC

You can improve your existing throne with the firm support and comfort of 1st Chair seats.

**668,00**

### 1ST CHAIR ROUND RIDER XL SEAT



#### HTS8B

You can improve your existing throne with the firm support and comfort of 1st Chair seats.

**668,00**

### 1ST CHAIR ROUND RIDER XL SEAT -Red-



#### HTS8R

You can improve your existing throne with the firm support and comfort of 1st Chair seats.

**668,00**

### 1ST CHAIR ERGO-RIDER SEAT -Cloth Top-



#### HTS7BC

You can improve your existing throne with the firm support and comfort of 1st Chair seats.

**668,00**

### 1ST CHAIR ERGO-RIDER SEAT



#### HTS7B

You can improve your existing throne with the firm support and comfort of 1st Chair seats.

**668,00**

### 1ST CHAIR GLIDE RIDER SEAT -Cloth Top-



#### HTS5BCN

You can improve your existing throne with the firm support and comfort of 1st Chair seats.

**668,00**

### 1ST CHAIR WIDE RIDER SEAT -Cloth Top-



#### HTS5BC

You can improve your existing throne with the firm support and comfort of 1st Chair seats.

**668,00**

### 1ST CHAIR WIDE RIDER SEAT



#### HTS5B

You can improve your existing throne with the firm support and comfort of 1st Chair seats.

**668,00**

### 1ST CHAIR ROUND RIDER SEAT -Cloth Top-



#### HTS4BC

You can improve your existing throne with the firm support and comfort of 1st Chair seats.

**499,00**

### 1ST CHAIR ROUND RIDER SEAT



#### HTS4B

You can improve your existing throne with the firm support and comfort of 1st Chair seats.

**499,00**

## 1ST CHAIR THRONE BASE -HYDRAULIX-



### HSB5N

\*Seat holder included.

You can improve your existing throne or seat by changing the legs to one of the 1st Chair individual throne bases. The Hydraulix throne base comes with a seat holder with an adjustment lever.

**994,00**

## 1ST CHAIR THRONE BASE -Quartet-



### HSB4N

You can improve your existing throne or seat by changing the legs to one of the 1st Chair individual throne bases. (diameter of upper rods: 22.2mm).

**898,00**

## 1ST CHAIR THRONE BASE -Trio-



### HSB3N

You can improve your existing throne or seat by changing the legs to one of the 1st Chair individual throne bases. (diameter of upper rods: 22.2mm).

**807,00**

## 1ST CHAIR THRONE BASE -Trio-



### HSB3

for Round Rider Series

You can improve your existing throne or seat by changing the legs to one of the 1st Chair individual throne bases. (diameter of upper rods: 22.2mm).

**712,00**

## 1ST CHAIR BACKREST ATTACHMENT



### HTB5B

for any 1st Chair thrones

Sitting on a throne for a long period of time is tough on your back. The HTB5B can be adjusted up and down AND forward AND it can be detached from the seat when the gig is done. Slick!

**569,00**

## TAMA LOGO STICKER -White-



### TLSxxWH

TLS120WH 60mm x 280mm  
 TLS100WH 50mm x 230mm  
 TLS80WH 40mm x 190mm  
 TLS70WH 35mm x 150mm

**20,00**  
**19,00**  
**19,00**  
**19,00**

## TAMA LOGO STICKER -Black-



### TLSxxBK

TLS120BK 60mm x 280mm  
 TLS100BK 50mm x 230mm  
 TLS80BK 40mm x 190mm  
 TLS70BK 35mm x 150mm

**20,00**  
**19,00**  
**19,00**  
**19,00**

## MEMORY LOCK



### ML11

for 10.5mm diameter L-rod

**43,00**

## MEMORY LOCK



### ML12

for 10.5-12mm diameter boom arm

**43,00**

## MEMORY LOCK



### ML191C

for 19.1mm diameter pipe

**57,00**

## MEMORY LOCK



### ML191N

for 19.1mm diameter pipe

**33,00**

## MEMORY LOCK



### ML222C

for 22.2mm diameter pipe

**57,00**

## MEMORY LOCK



### ML222NT

for 22.2mm diameter pipe

**33,00**

## MEMORY LOCK



### ML254TC

for 25.4mm diameter pipe

**33,00**

## MEMORY LOCK



### ML254C

for 25.4mm diameter pipe

**57,00**

## MEMORY LOCK



### ML28C

for 28.6mm diameter pipe

**71,00**

## QUICK-SET CYMBAL MATE



### QC8

(M8)

**26,00**

## QUICK-SET CYMBAL MATE (4pcs/set)



### QC8-B4

(M8: 4pcs/pack)

**77,00**

## CYMBAL MATE



### CM8P

(M8: 2pcs/pack)

**15,00**

## RING-TRUE FELT for STAR HARDWARE



### RTF35P

(2pcs/pack)

**54,00**



## FELT WASHER



**7081P**

(2pcs/pack)

**15,00**

## REVERSIBLE CYMBAL BOTTOM



**RB8P**

(M8: 2pcs/pack)

**15,00**

## STAR HARDWARE CYMBAL BOTTOM



**CB8P**

(M8: 2pcs/pack)

**30,00**

## STAR HARDWARE CYMBAL PROTECTION SLEEVE



**CPS8P**

(M8: 2pcs/pack)

**34,00**

## HAT STACK



**CSH5**

- Easily attach a small cymbal to hi-hat rod measuring up to 7mm in diameter
- Compact size and lightweight for easy transport and storage - 25mm (1") diameter x 40mm (1.5") height
- Ability to adjust cymbal sustain

**65,00**

## SIZZLE TOUCH DROP CLUTCH



**STDC7**

TAMA's Sizzle Touch Drop Clutch allows you to adjust the gap between the top and bottom cymbals, allowing for fine adjustments to achieve the desired open sound.

**251,00**

## QUICK-SET HI-HAT CLUTCH



**QHC7**

With just one touch, the Quick-Set Clutch can be attached or removed - simply push the button on the side of the clutch.  
(Fits 7mm or smaller diameter pull rod)

**151,00**

## SWING LOCK CLUTCH



**SLC08**

This allows the top hi-hat cymbal to float more freely, maximizing the natural resonance of the cymbals.  
(Fits 6.3mm diameter pull rod)

**130,00**

## SECURITY CLUTCH



**CL08**

Having your hi-hat clutch come loose is now a thing of the past with TAMA's Security Clutch. When the T-bolt is tightened, bottom lock nut and top section press on the rod for complete security.  
(Fits 6.3mm diameter pull rod)

**75,00**

## HI-HAT TENSION RODS



**HH905-3/HH905D3S**

Tension Rod w/ Plastic Nut (M6)

HH905-3 (Long / 500mm (19 11/16"))  
**26,00**

HH905D3S (Short / 350mm (13 3/4"))  
**26,00**

## REMOTE HI-HAT STAND CABLE

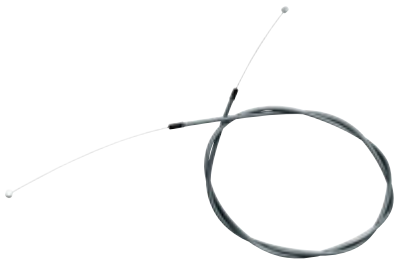

### HH905RH2L/HH905RH2S

Exchangeable Cable for HH905RH

HH905RH2L (Long / 2,300mm (90 1/2"))  
**238,00**

HH905RH2S (Short / 1,200mm (47 1/4"))  
**195,00**

## HI-HAT CLUTCH FELT WASHERS



### CL08-13P

(2pcs/pack)

**19,00**

## QUICK-LOCK TOM BRACKET



### MQMP-TCH

(for tom tom/Chrome)

-Quick and easy setup in position  
-Enhanced resonance with rubber lining

**195,00**

## QUICK-LOCK TOM BRACKET



### MQMP-TBN

(for tom tom/Black Nickel)

-Quick and easy setup in position  
-Enhanced resonance with rubber lining

**195,00**

## QUICK-LOCK TOM BRACKET



### MQMP-FCH

(for floor tom/Chrome)

-Quick and easy setup in position  
-Enhanced resonance with rubber lining

**164,00**

## QUICK-LOCK TOM BRACKET



### MQMP-FBN

(for floor tom/Black Nickel)

-Quick and easy setup in position  
-Enhanced resonance with rubber lining

**164,00**

## SOUND FOCUS PAD -for Cocktail-JAM-



### SFP530

Bass Drum Mute for Cocktail-JAM kits

**139,00**

## TAMA LOGO T-SHIRT BLACK



### TAMT004

Available size: S/M/L/XL/XXL

TAMT004S  
TAMT004M  
TAMT004L  
TAMT004XL  
TAMT004XXL

**108,00**

## TAMA "T" LOGO T-SHIRT BLACK



### TAMT006

Available size: S/M/XL/XXL

TAMT006S  
TAMT006M  
TAMT006XL  
TAMT006XXL

**86,00**

## TAMA BLACKLOGO T-SHIRT BLACK



### TAMT007

Available size: M/L/XL/XXL

TAMT007M  
TAMT007L  
TAMT007XL  
TAMT007XXL

**108,00**

## TAMA "T" LOGO LONG SLEEVED T-SHIRT BLACK



### TAML001

Available size: S/M/L/XL/XXL

TAML001S  
TAML001M  
TAML001L  
TAML001XL  
TAML001XXL

**130,00**

## TAMA LOGO PULLOVER HOODIE



### TAMP001

Available size: S/M/L/XL/XXL

TAMP001S  
TAMP001M  
TAMP001L  
TAMP001XL  
TAMP001XXL

**230,00**

## TAMA WATER BOTTLE



### TAMB001

Capacity: 500ml / 16.9oz  
-Materials: Tritan (Bottle) / Polypropylene (Lid)  
- Upper temperature tolerance: 100°C / 212°F  
- Lower temperature tolerance: -10°C / 14°F  
- BPA Free

**86,00**

## TAMA MUG



### TAMM002

-Size: 72mm (D) x 90mm (H)  
(2 3/4" x 3 1/2")

-Material: Stoneware

**65,00**

## TAMA LOGO LANYARD



### TNKS001

-Length: 500 mm  
-Width: 15 mm  
-Safety breakaway release  
-Material: Polyester

**39,00**

## TAMA LOGO TOWEL BLACK



### TTWL001

MADE IN JAPAN

-Length: 200 mm  
-Width: 1,100 mm  
-Material: Cotton

**86,00**

## TAMA LOGO PIN



### TMPIN001

NEW

-Length: 10.5 mm  
-Width: 38 mm  
-Height: 10mm  
-Material: Nickel Plated Brass

**26,00**

# DRUM STICKS

TAMA drum sticks are molded under strict quality control standards from carefully selected wood materials and are renowned for their consistent high quality.

## ORIGINAL SERIES STICK -Japanese Oak-

### 0213-B

MADE IN JAPAN

Diameter: 13mm (0.510")  
Length: 406mm (16")  
Tip Style: Ball



52,00

## ORIGINAL SERIES STICK -Japanese Oak-

### 0214-B

MADE IN JAPAN

Diameter: 14mm (0.550")  
Length: 406mm (16")  
Tip Style: Ball



52,00

## ORIGINAL SERIES STICK -Japanese Oak-

### 0215-B

MADE IN JAPAN

Diameter: 15mm (0.590")  
Length: 406mm (16")  
Tip Style: Ball



52,00

## ORIGINAL SERIES STICK -Japanese Oak-

### 0216-B

MADE IN JAPAN

Diameter: 16mm (0.630")  
Length: 406mm (16")  
Tip Style: Ball



52,00

## ORIGINAL SERIES STICK -Japanese Oak-

### 0213-P

MADE IN JAPAN

Diameter: 13mm (0.510")  
Length: 406mm (16")  
Tip Style: Popular



52,00

## ORIGINAL SERIES STICK -Japanese Oak-

### 0214-P

MADE IN JAPAN

Diameter: 14mm (0.550")  
Length: 406mm (16")  
Tip Style: Popular



52,00

## ORIGINAL SERIES STICK -Japanese Oak-

### 0215-P

MADE IN JAPAN

Diameter: 15mm (0.590")  
Length: 406mm (16")  
Tip Style: Popular



52,00

## ORIGINAL SERIES STICK -Japanese Oak-

### 0214-S

MADE IN JAPAN

Diameter: 14mm (0.550")  
Length: 406mm (16")  
Tip Style: Small



52,00

## ORIGINAL SERIES STICK -Japanese Oak-

### 0215-S

MADE IN JAPAN

Diameter: 15mm (0.590")  
Length: 406mm (16")  
Tip Style: Small



52,00

## TRADITIONAL SERIES STICK -Japanese Oak-

### 7A

MADE IN JAPAN

Diameter: 13mm (0.510")  
Length: 390mm (15 3/8")  
Tip Style: 7A



52,00

## TRADITIONAL SERIES STICK -Japanese Oak-

### 7AN

MADE IN JAPAN

Diameter: 13mm (0.510")  
Length: 390mm (15 3/8")  
Tip Style: 7A (Nylon)



56,00

## TRADITIONAL SERIES STICK -Japanese Oak-

### 5A

MADE IN JAPAN

Diameter: 14mm (0.550")  
Length: 406mm (16")  
Tip Style: 5A



52,00

## TRADITIONAL SERIES STICK -Japanese Oak-

### 5AN

MADE IN JAPAN

Diameter: 14mm (0.550")  
Length: 406mm (16")  
Tip Style: 5A (Nylon)



56,00

## TRADITIONAL SERIES STICK -Japanese Oak-

### 8A

MADE IN JAPAN

Diameter: 14mm (0.550")  
Length: 406mm (16")  
Tip Style: 8A



52,00

## TRADITIONAL SERIES STICK -Japanese Oak-

### 5B

MADE IN JAPAN

Diameter: 15mm (0.590")  
Length: 406mm (16")  
Tip Style: 5B



52,00

## TRADITIONAL SERIES STICK -Japanese Oak-

### 5BN

MADE IN JAPAN

Diameter: 15mm (0.590")  
Length: 406mm (16")  
Tip Style: 5B (Nylon)



56,00

## TRADITIONAL SERIES STICK -American Hickory-

### H7A

MADE IN JAPAN

Diameter: 13mm (0.510")  
Length: 390mm (15 3/8")  
Tip Style: 7A



56,00

## TRADITIONAL SERIES STICK -American Hickory-

### H5A

MADE IN JAPAN

Diameter: 14mm (0.550")  
Length: 406mm (16")  
Tip Style: 5A



56,00



## TRADITIONAL SERIES STICK -American Hickory-

### H8A

MADE IN JAPAN

Diameter: 14mm (0.550")  
Length: 406mm (16")  
Tip Style: 8A



56,00

## TRADITIONAL SERIES STICK -American Hickory-

### H5B

MADE IN JAPAN

Diameter: 15mm (0.590")  
Length: 406mm (16")  
Tip Style: 5B



56,00

## OAK LAB SERIES -Smash-

### OL-SM

MADE IN JAPAN

Weight and balance for huge power.

Diameter: 15mm (0.590")  
Length: 419mm (16 1/2")  
Tip Style: Acorn



52,00

## OAK LAB SERIES -Resonator-

### OL-RE

MADE IN JAPAN

Heavy for rich tones. Quick rebound.

Diameter: 15.25mm (0.600")  
Length: 410mm (16 5/32")  
Tip Style: Arrow



52,00

## OAK LAB SERIES -Fast Blast-

### OL-FA

MADE IN JAPAN

(Natural / Uncoated)  
Modified 5A for more speed. Large tip and Oak enhances volume.

Diameter: 14mm (0.550")  
Length: 406mm (16")  
Tip Style: Large Ball



52,00

## OAK LAB SERIES -Swingin'-

### OL-SW

MADE IN JAPAN

Oak provides a bright cymbal tone and enhanced cross stick sound.

Diameter: 12.75mm (0.500")  
Length: 403mm (15 7/8")  
Tip Style: Oval



52,00

## OAK LAB SERIES -Full Balance-

### OL-FU

MADE IN JAPAN

Weighted for accuracy and control.

Diameter: 14.5mm (0.570")  
Length: 406mm (16")  
Tip Style: True Round



52,00

## REDZONE -Japanese Oak-

### 5ARZ

MADE IN JAPAN

(Silver Logo)

Diameter: 14mm (0.550")  
Length: 419mm (16 1/2")  
Tip Style: 5A (Nylon)



56,00

## REDZONE -Japanese Oak-

### 5BRZ

MADE IN JAPAN

(Silver Logo)

Diameter: 15mm (0.590")  
Length: 419mm (16 1/2")  
Tip Style: 5B (Nylon)



56,00

## RHYTHMIC FIRE -Japanese Oak-

### 7A-F

MADE IN JAPAN

(Natural)

Diameter: 13mm (0.510")  
Length: 390mm (15 3/8")  
Tip Style: 7A



52,00

## RHYTHMIC FIRE -Japanese Oak-

### 5A-F

(Natural)

Diameter: 14mm (0.550")  
Length: 406mm (16")  
Tip Style: 5A

MADE IN JAPAN



52,00

## RHYTHMIC FIRE -Japanese Oak-

### 5B-F

(Natural)

Diameter: 15mm (0.590")  
Length: 406mm (16")  
Tip Style: 5B

MADE IN JAPAN



52,00

## RHYTHMIC FIRE -Japanese Oak-

### 7A-F-BS

(Black, Silver Pattern)

Diameter: 13mm (0.510")  
Length: 390mm (15 3/8")  
Tip Style: 7A

MADE IN JAPAN



60,00

## RHYTHMIC FIRE -Japanese Oak-

### 5A-F-BS

(Black, Silver Pattern)

Diameter: 14mm (0.550")  
Length: 406mm (16")  
Tip Style: 5A

MADE IN JAPAN



60,00

## RHYTHMIC FIRE -Japanese Oak-

### 5B-F-BS

(Black, Silver Pattern)

Diameter: 15mm (0.590")  
Length: 406mm (16")  
Tip Style: 5B

MADE IN JAPAN



60,00

## RHYTHMIC FIRE -Japanese Oak-

### 7A-F-BR

(Black, Red Pattern)

Diameter: 13mm (0.510")  
Length: 390mm (15 3/8")  
Tip Style: 7A

MADE IN JAPAN



60,00

## RHYTHMIC FIRE -Japanese Oak-

### 5A-F-BR

(Black, Red Pattern)

Diameter: 14mm (0.550")  
Length: 406mm (16")  
Tip Style: 5A

MADE IN JAPAN



60,00

## RHYTHMIC FIRE -Japanese Oak-

### 5B-F-BR

(Black, Red Pattern)

Diameter: 15mm (0.590")  
Length: 406mm (16")  
Tip Style: 5B

MADE IN JAPAN



60,00

## STICKS OF DOOM -Japanese Oak-

### 7A-S

(Natural)

Diameter: 13mm (0.510")  
Length: 390mm (15 3/8")  
Tip Style: 7A

MADE IN JAPAN



52,00

## STICKS OF DOOM -Japanese Oak-

### 5A-S

(Natural)

Diameter: 14mm (0.550")  
Length: 406mm (16")  
Tip Style: 5A

MADE IN JAPAN



52,00

## STICKS OF DOOM -Japanese Oak-

### 5B-S

(Natural)

Diameter: 15mm (0.590")  
Length: 406mm (16")  
Tip Style: 5B

MADE IN JAPAN



52,00

## STICKS OF DOOM -Japanese Oak-

### 7A-S-BS

(Black, Silver Pattern)

Diameter: 13mm (0.510")  
Length: 390mm (15 3/8")  
Tip Style: 7A

MADE IN JAPAN



60,00

## STICKS OF DOOM -Japanese Oak-

### 5A-S-BS

(Black, Silver Pattern)

Diameter: 14mm (0.550")  
Length: 406mm (16")  
Tip Style: 5A

MADE IN JAPAN



60,00

## STICKS OF DOOM -Japanese Oak-

### 5B-S-BS

(Black, Silver Pattern)

Diameter: 15mm (0.590")  
Length: 406mm (16")  
Tip Style: 5B

MADE IN JAPAN



60,00

## SUEDE-GRIP DRUM STICKS -Japanese Oak-

### 5A-SG

(SUEDE-GRIP Finish)

Diameter : 14mm (0.550")  
Length : 406mm (16")  
Tip Style : 5A

MADE IN JAPAN



56,00

## SUEDE-GRIP DRUM STICKS -Japanese Oak-

### 5B-SG

(SUEDE-GRIP Finish)

Diameter : 15mm (0.590")  
Length : 406mm (16")  
Tip Style : 5B

MADE IN JAPAN



56,00

## DIRK VERBEUREN MODEL -Japanese Oak-

### 0-DVM2

Dirk Verbeuren (MEGADETH)

Diameter: 16mm (0.630")  
Length: 406mm (16")

NEW MADE IN JAPAN



47,00

## MARIO DUPLANTIER MODEL -American Hickory-

### H-MD

Mario Duplantier (Gojira)

Diameter: 16.5mm (0.649")  
Length: 432mm (17")

MADE IN JAPAN



52,00

## ALEX RÜDINGER MODEL -American Hickory-

### H-RUDI

Alex Rüdinger

Diameter: 16mm (0.630")  
Length: 416mm (16 3/8")  
Non-Slipping Lacquer Finish

MADE IN JAPAN



65,00

## ANUP SASTRY MODEL -American Hickory-

### H-AS

Anup Sastry

Diameter: 16mm (0.630")  
Length: 432mm (17")

MADE IN JAPAN



52,00

# MARCHING PERCUSSION

After a long period of planning and experimentation, TAMA Marching Percussion is finally complete. High durability, various unique features for function and comfort, and revolutionary improvements allow total customized playability for everyone.

## FIELDSTAR MARCHING SNARE DRUMS



Color: Deeper Purple (DPP)

### MS1412L

- Shell Materials : Maple 6ply 5mm
- Number of Lugs : 12 lugs with aluminum tube pipes
- Weight :  
MS1409 14" x 9" 12.9 lbs (5.9kg)  
MS1412 14" x 12" 14.2 lbs (6.5kg)
- Strainer : Low Profile Strainer
- Snare Structure : Less stress with free floating and detachable gut frame
- Tension Rods and Washers : 6 mm strong tension rods with double washers
- Batter Side Edge Ring : Lightweight Magnesium Edge Ring for super high-pitch tuning
- Bottom Side Edge : With reinforcement ring
- Snare Guts : 11 Guts with Detachable Gut Frame
- Snare Mutes : 2 Buzz Killer Mutes included
- Hoops : Aluminum die-cast hoop
- Hardware Finish : Chrome
- Shell Finishes : 17 lacquer finishes & 1 wrap finish
- Stable Position Ring : Allows for easy replacement of the bottom head
- Legs : 2 aluminum legs prevent damage to the bottom hoop

### Lacquer Finishes

Model No.	Size		
MS1409L	14"x9" MARCHING SNARE DRUM		5.204,00
MS1412L	14"x12" MARCHING SNARE DRUM		5.204,00

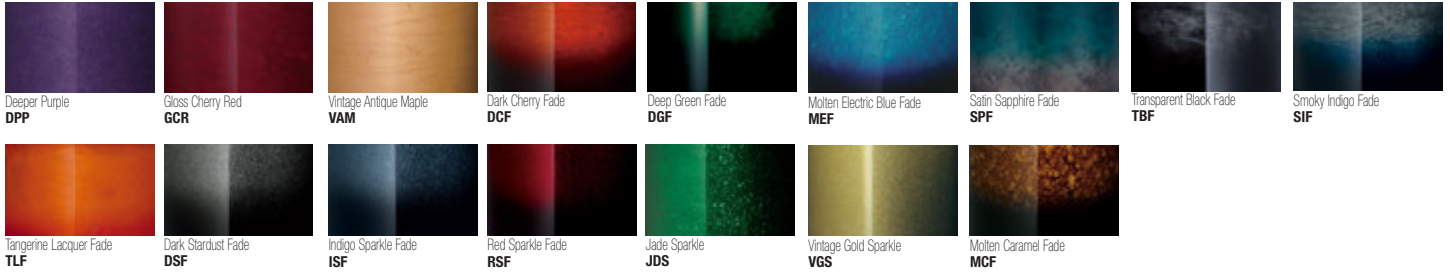

### Lacquer Finish -Satin Black-

Model No.	Size		
MS1409T	14"x9" MARCHING SNARE DRUM		4.422,00
MS1412T	14"x12" MARCHING SNARE DRUM		4.422,00



Satin Black  
**SBK**

### Wrap Finish -Sugar White-

Model No.	Size		
MS1409K	14"x9" MARCHING SNARE DRUM		4.422,00
MS1412K	14"x12" MARCHING SNARE DRUM		4.422,00



Sugar White  
**SGW**

# FIELDSTAR RUDIMENT MARCHING TENOR DRUMS



Color: Satin Black (SBK)

## MD680234T

- Shell Materials : Maple 6ply 5mm w/reinforcement rings on batter side
- Shell Depth :
- Spock 6"x5.5", 6"x7", 8"x7"
- Standard Toms 8"x7.5", 10"x8", 12"x9.5", 13"x11", 14x11.5" with Power Cut
- Corps Depth Toms: 10"x9.5", 12"x11", 13"x12.5", 14"x13" with Power Cut
- Lugs : Die-cast aluminum lugs
- Number of Lugs : 6" = 4, 8" = 5, 10" = 6, 12", 13", 14" = 8
- Hoops : 2.3 mm Steel Mighty Hoop
- Edge Guard : Included
- Shell Inside : Clear painted to protect inner shell
- Shell Finishes : 17 lacquer finishes & 1 wrap finish
- Hardware Finish : Chrome

### Lacquer Finishes

Model No.	Size		
MT8023L	8"-10"-12"-13" SMALL QUAD DRUMS		8.285,00
MT0234L	10"-12"-13"-14" LARGE QUAD DRUMS		8.979,00
MT68023L	6"-8"-10"-12"-13" SMALL QUINT DRUMS		9.457,00
MT60234L	6"-10"-12"-13"-14" LARGE QUINT DRUMS		10.195,00
MD60234L	6"-10"-12"-13"-14" LARGE QUINT DRUMS (CORP-DEPTH)		10.195,00
MT80234L	8"-10"-12"-13"-14" LARGE QUINT DRUMS		10.325,00
MT668023L	6"-6"-8"-10"-12"-13" SMALL SEXTET DRUMS		10.889,00
MT660234L	6"-6"-10"-12"-13"-14" LARGE SEXTET DRUMS		11.366,00
MD660234L	6"-6"-10"-12"-13"-14" LARGE SEXTET DRUMS (CORP-DEPTH)		11.366,00
MT680234L	6"-8"-10"-12"-13"-14" LARGE SEXTET DRUMS		11.670,00
MD680234L	6"-8"-10"-12"-13"-14" LARGE SEXTET DRUMS (CORP-DEPTH)		11.670,00
MT602L	6"-10"-12" TRIO DRUMS		6.679,00

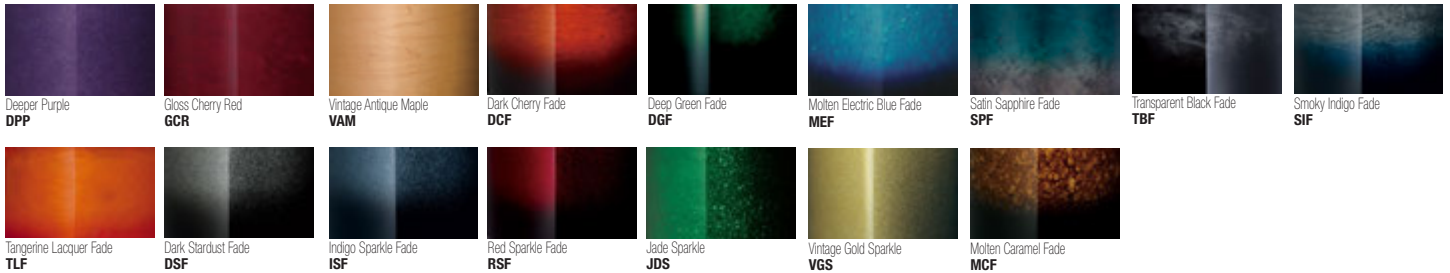

### Lacquer Finish -Satin Black-

Model No.	Size		
MT8023T	8"-10"-12"-13" SMALL QUAD DRUMS		6.245,00
MT0234T	10"-12"-13"-14" LARGE QUAD DRUMS		6.679,00
MT68023T	6"-8"-10"-12"-13" SMALL QUINT DRUMS		7.200,00
MT60234T	6"-10"-12"-13"-14" LARGE QUINT DRUMS		7.634,00
MD60234T	6"-10"-12"-13"-14" LARGE QUINT DRUMS (CORP-DEPTH)		7.634,00
MT80234T	8"-10"-12"-13"-14" LARGE QUINT DRUMS		7.677,00
MT668023T	6"-6"-8"-10"-12"-13" SMALL SEXTET DRUMS		8.068,00
MT660234T	6"-6"-10"-12"-13"-14" LARGE SEXTET DRUMS		8.502,00
MD660234T	6"-6"-10"-12"-13"-14" LARGE SEXTET DRUMS (CORP-DEPTH)		8.502,00
MT680234T	6"-8"-10"-12"-13"-14" LARGE SEXTET DRUMS		8.893,00
MD680234T	6"-8"-10"-12"-13"-14" LARGE SEXTET DRUMS (CORP-DEPTH)		8.893,00
MT602T	6"-10"-12" TRIO DRUMS		5.160,00



### Wrap Finish -Sugar White-

Model No.	Size		
MT8023K	8"-10"-12"-13" SMALL QUAD DRUMS		6.245,00
MT0234K	10"-12"-13"-14" LARGE QUAD DRUMS		6.679,00
MT68023K	6"-8"-10"-12"-13" SMALL QUINT DRUMS		7.200,00
MT60234K	6"-10"-12"-13"-14" LARGE QUINT DRUMS		7.634,00
MD60234K	6"-10"-12"-13"-14" LARGE QUINT DRUMS (CORP-DEPTH)		7.634,00
MT80234K	8"-10"-12"-13"-14" LARGE QUINT DRUMS		7.677,00
MT668023K	6"-6"-8"-10"-12"-13" SMALL SEXTET DRUMS		8.068,00
MT660234K	6"-6"-10"-12"-13"-14" LARGE SEXTET DRUMS		8.502,00
MD660234K	6"-6"-10"-12"-13"-14" LARGE SEXTET DRUMS (CORP-DEPTH)		8.502,00
MT680234K	6"-8"-10"-12"-13"-14" LARGE SEXTET DRUMS		8.893,00
MD680234K	6"-8"-10"-12"-13"-14" LARGE SEXTET DRUMS (CORP-DEPTH)		8.893,00
MT602K	6"-10"-12" TRIO DRUMS		5.160,00





# FIELDSTAR FREEDOM MARCHING TENOR DRUMS



Color: Molten Caramel Fade (MCF)

## M668023TL

- Shell Materials : Maple 6ply 5mm w/reinforcement rings on batter side
- Shell Depth :
- Spock 6"x5.5", 6"x7", 8"x7"
- Standard Toms 8"x7.5", 10"x8", 12"x9.5", 13"x11", 14"x11.5" with Power Cut
- Corps Depth Toms: 10"x9.5", 12"x11", 13"x12.5", 14"x13" with Power Cut
- Lugs : Die-cast aluminum lugs
- Number of Lugs : 6" = 4, 8" = 5, 10" = 6, 12", 13", 14" = 8
- Hoops : 2.3 mm Steel Mighty Hoop
- Edge Guard : Included
- Adjusting Tom Angle : Adjusts by loosening 4 screws with tuning key
- Legs : Three Detachable Legs
- Shell Inside : Clear painted to protect inner shell
- Shell Finishes : 17 lacquer finishes & 1 wrap finish
- Hardware Finish : Chrome

### Lacquer Finishes

Model No.	Size		
M8023TL	8"-10"-12"-13" QUAD DRUMS		8.285,00
M68023TL	6"-8"-10"-12"-13" QUINT DRUMS		9.457,00
M668023TL	6"-6"-8"-10"-12"-13" SEXTET DRUMS		10.889,00
M0234TL	10"-12"-13"-14" QUAD DRUMS		8.979,00
M60234TL	6"-10"-12"-13"-14" QUINT DRUMS		10.195,00
M60234DL	6"-10"-12"-13"-14" QUINT DRUMS (CORP-DEPTH)		10.195,00
M80234TL	8"-10"-12"-13"-14" QUINT DRUMS		10.325,00
M660234TL	6"-6"-10"-12"-13"-14" SEXTET DRUMS		11.366,00
M660234DL	6"-6"-10"-12"-13"-14" SEXTET DRUMS (CORP-DEPTH)		11.366,00
M680234TL	6"-8"-10"-12"-13"-14" SEXTET DRUMS		11.670,00
M680234DL	6"-8"-10"-12"-13"-14" SEXTET DRUMS (CORP-DEPTH)		11.670,00
M4TL	14"x11.5" SOLO TENOR DRUM		3.207,00

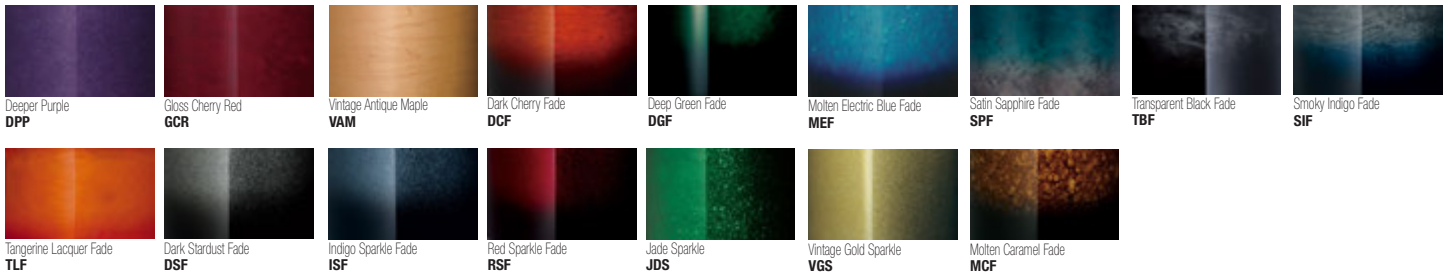

### Lacquer Finish -Satin Black-

Model No.	Size		
M8023TT	8"-10"-12"-13" QUAD DRUMS		6.245,00
M68023TT	6"-8"-10"-12"-13" QUINT DRUMS		7.200,00
M668023TT	6"-6"-8"-10"-12"-13" SEXTET DRUMS		8.068,00
M0234TT	10"-12"-13"-14" QUAD DRUMS		6.679,00
M60234TT	6"-10"-12"-13"-14" QUINT DRUMS		7.634,00
M60234DT	6"-10"-12"-13"-14" QUINT DRUMS (CORP-DEPTH)		7.634,00
M80234TT	8"-10"-12"-13"-14" QUINT DRUMS		7.677,00
M660234TT	6"-6"-10"-12"-13"-14" SEXTET DRUMS		8.502,00
M660234DT	6"-6"-10"-12"-13"-14" SEXTET DRUMS (CORP-DEPTH)		8.502,00
M680234TT	6"-8"-10"-12"-13"-14" SEXTET DRUMS		8.893,00
M680234DT	6"-8"-10"-12"-13"-14" SEXTET DRUMS (CORP-DEPTH)		8.893,00
M4TT	14"x11.5" SOLO TENOR DRUM		2.383,00



Satin Black  
SBK

### Wrap Finish -Sugar White-

Model No.	Size		
M8023TK	8"-10"-12"-13" QUAD DRUMS		6.245,00
M68023TK	6"-8"-10"-12"-13" QUINT DRUMS		7.200,00
M668023TK	6"-6"-8"-10"-12"-13" SEXTET DRUMS		8.068,00
M0234TK	10"-12"-13"-14" QUAD DRUMS		6.679,00
M60234TK	6"-10"-12"-13"-14" QUINT DRUMS		7.634,00
M60234DK	6"-10"-12"-13"-14" QUINT DRUMS (CORP-DEPTH)		7.634,00
M80234TK	8"-10"-12"-13"-14" QUINT DRUMS		7.677,00
M660234TK	6"-6"-10"-12"-13"-14" SEXTET DRUMS		8.502,00
M660234DK	6"-6"-10"-12"-13"-14" SEXTET DRUMS (CORP-DEPTH)		8.502,00
M680234TK	6"-8"-10"-12"-13"-14" SEXTET DRUMS		8.893,00
M680234DK	6"-8"-10"-12"-13"-14" SEXTET DRUMS (CORP-DEPTH)		8.893,00
M4TK	14"x11.5" SOLO TENOR DRUM		2.383,00



Sugar White  
SGW

# FIELDSTAR MARCHING BASS DRUMS



Color: Satin Black (SBK)

## MB2214T

- Shell Materials : Maple 8ply 6mm
- Weight :
  - MB1414 14"x14" 14.5lbs (6.6kg)
  - MB1614 16"x14" 15.7lbs (7.1kg)
  - MB1814 18"x14" 16.5lbs (7.5kg)
  - MB2014 20"x14" 19.0lbs (8.6kg)
  - MB2214 22"x14" 20.1lbs (9.1kg)
  - MB2414 24"x14" 21.3lbs (9.7kg)
  - MB2614 26"x14" 22.5lbs (10.2kg)
  - MB2814 28"x14" 23.7lbs (10.8kg)
  - MB3014 30"x14" 24.9lbs (11.3kg)

- Attachment for carrier : Noiseless carrier attachment
- Lugs : Die-cast aluminum high-tension lugs
- Number of lugs : 14" - 18" = 8 lugs, 20" - 28" = 10 lugs, 30" = 12 lugs
- Claw Hooks : Designed with superior strength for high-pitch tuning
- Hoops : High-gloss black lacquer finish
- Shell Finishes : 17 lacquer finishes & 1 wrap finish
- Hardware Finish : Chrome

### Lacquer Finishes

Model No.	Size		
MB1414L	14"x14" MARCHING BASS DRUM		3,902,00
MB1614L	16"x14" MARCHING BASS DRUM		4,205,00
MB1814L	18"x14" MARCHING BASS DRUM		4,553,00
MB2014L	20"x14" MARCHING BASS DRUM		5,377,00
MB2214L	22"x14" MARCHING BASS DRUM		5,551,00
MB2414L	24"x14" MARCHING BASS DRUM		5,985,00
MB2614L	26"x14" MARCHING BASS DRUM		6,419,00
MB2814L	28"x14" MARCHING BASS DRUM		6,766,00
MB3014L	30"x14" MARCHING BASS DRUM w/o drum heads		8,849,00

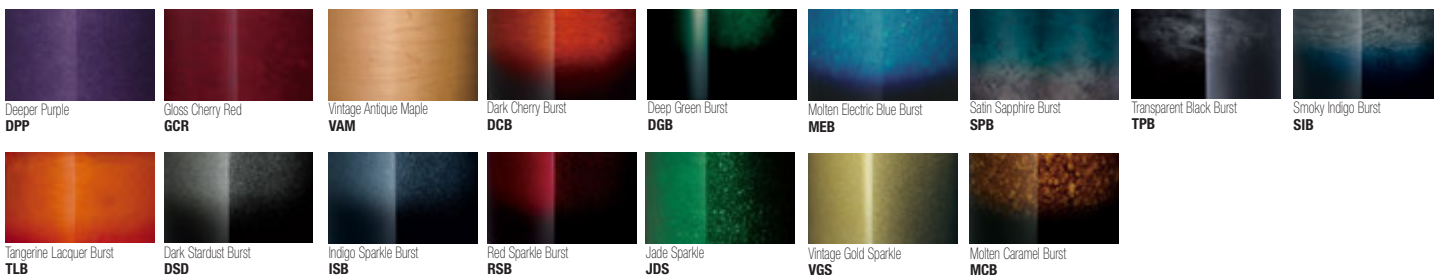

### Lacquer Finishes -Satin Black-

Model No.	Size		
MB1414T	14"x14" MARCHING BASS DRUM		2,990,00
MB1614T	16"x14" MARCHING BASS DRUM		3,251,00
MB1814T	18"x14" MARCHING BASS DRUM		3,641,00
MB2014T	20"x14" MARCHING BASS DRUM		4,075,00
MB2214T	22"x14" MARCHING BASS DRUM		4,205,00
MB2414T	24"x14" MARCHING BASS DRUM		4,422,00
MB2614T	26"x14" MARCHING BASS DRUM		4,900,00
MB2814T	28"x14" MARCHING BASS DRUM		5,073,00
MB3014T	30"x14" MARCHING BASS DRUM w/o drum heads		6,245,00



### Wrap Finish -Sugar White-

Model No.	Size		
MB1414K	14"x14" MARCHING BASS DRUM		2,990,00
MB1614K	16"x14" MARCHING BASS DRUM		3,251,00
MB1814K	18"x14" MARCHING BASS DRUM		3,641,00
MB2014K	20"x14" MARCHING BASS DRUM		4,075,00
MB2214K	22"x14" MARCHING BASS DRUM		4,205,00
MB2414K	24"x14" MARCHING BASS DRUM		4,422,00
MB2614K	26"x14" MARCHING BASS DRUM		4,900,00
MB2814K	28"x14" MARCHING BASS DRUM		5,073,00
MB3014K	30"x14" MARCHING BASS DRUM w/o drum heads		6,245,00



## STARLIGHT MARCHING SNARE DRUMS



Color: Satin Black (SBK)

### R1412SL

- Shell : Birch 8mm 8ply
- Hoop : 2.3mm Steel Mighty Hoop
- Number of Lugs : 12 lugs with aluminum tube pipes
- Strainer : Quick touch snare strainer
- Batter Side Edge Ring : Aluminum die-cast edge ring for super high-pitch tuning
- Snare Wires : 20-strand Carbon Steel Snappy Snares

#### Lacquer Finish -Satin Black-

Model No.	Size		
R1412SL	14"x12" MARCHING SNARE DRUM		2.383,00

Satin Black  
SBK

#### Wrap Finish -Sugar White-

Model No.	Size		
R1412SK	14"x12" MARCHING SNARE DRUM		2.339,00

Sugar White  
SGW

## STARLIGHT MARCHING TENOR DRUMS



Color: Sugar White (SGW)

### R8023TK

- Shell : Birch 8mm 8ply
- Hoop : 1.6mm Steel Triple Flanged
- Adjusting Tom Angle (for Quad)
- Edge Guard included

#### Lacquer Finish -Satin Black-

Model No.	Size		
R8023TL	8"-10"-12"-13" QUAD DRUMS		3.641,00
R802TL	8"-10"-12" TRIO DRUMS		2.730,00
R4TL	14"x11.5" SOLO TENOR DRUM		1.645,00
R0655TLP	6"x5.5" TOM FOR TENOR DRUM		647,00

#### Wrap Finish -Sugar White-

Model No.	Size		
R8023TK	8"-10"-12"-13" QUAD DRUMS		3.511,00
R802TK	8"-10"-12" TRIO DRUMS		2.686,00
R4TK	14"x11.5" SOLO TENOR DRUM		1.558,00
R0655TKP	6"x5.5" TOM FOR TENOR DRUM		647,00

## STARLIGHT MARCHING BASS DRUMS



Color: Sugar White (SGW)

### R2214BK

- Shell : Birch 7mm 7ply
- Attachment for carrier : Noiseless carrier attachment
- Lug : Die-cast aluminum high-tension lugs
- Number of lugs : 16" - 18" = 8 lugs, 20" - 28" = 10 lugs
- Claw Hook : Designed with superior strength for high-pitch tuning
- Hoop : High-gloss black lacquer finish

#### Lacquer Finish -Satin Black-

Model No.	Size		
R1614BL	16"x14" MARCHING BASS DRUM		2.513,00
R1814BL	18"x14" MARCHING BASS DRUM		2.686,00
R2014BL	20"x14" MARCHING BASS DRUM		3.077,00
R2214BL	22"x14" MARCHING BASS DRUM		3.207,00
R2414BL	24"x14" MARCHING BASS DRUM		3.337,00
R2614BL	26"x14" MARCHING BASS DRUM		3.685,00
R2814BL	28"x14" MARCHING BASS DRUM		3.858,00

#### Wrap Finish -Sugar White-

Model No.	Size		
R1614BK	16"x14" MARCHING BASS DRUM		2.469,00
R1814BK	18"x14" MARCHING BASS DRUM		2.643,00
R2014BK	20"x14" MARCHING BASS DRUM		3.034,00
R2214BK	22"x14" MARCHING BASS DRUM		3.164,00
R2414BK	24"x14" MARCHING BASS DRUM		3.294,00
R2614BK	26"x14" MARCHING BASS DRUM		3.641,00
R2814BK	28"x14" MARCHING BASS DRUM		3.728,00

Satin Black  
SBK

Sugar White  
SGW

## SILVER ARMOR CARRIER FOR SNARE DRUM



### CSASDT

- Sliding Height Adjustment
- Safety Lock Mount
- Positioning Bar
- Belly Pad
- Shoulder Pipe Adjustment
- Backrest Adjustment
- Movable Pad

**2.035,00**

## SILVER ARMOR CARRIER FOR TENOR DRUM



### CSATNT

- Sliding Height Adjustment
- Safety Lock Mount
- Positioning Bar
- Drum Lift Bumper
- Belly Pad
- Shoulder Pipe Adjustment
- Backrest Adjustment
- Movable Pad

**2.035,00**

## SILVER ARMOR CARRIER FOR BASS DRUM



### CSABDT

- Sliding Height Adjustment
- Safety Lock Mount
- Two-way Support Bar
- Belly Pad
- Shoulder Pipe Adjustment
- Backrest Adjustment
- Movable Pad

**2.035,00**

## SILVER ARMOR CARRIER "J-BAR TYPE" FOR SNARE DRUM



### CSASDM

- Sliding Height Adjustment
- Belly Pad
- Shoulder Pipe Adjustment
- Backrest Adjustment
- Movable Pad
- Suitable for general J-bar type carrier for Snare drums that have 14mm diameter rod
- Not fit to Tama Marching Snare Drums

**2.035,00**

## SILVER ARMOR CARRIER "J-BAR TYPE" FOR TENOR DRUM



### CSATNM

- Sliding Height Adjustment
- Drum Lift Bumper
- Belly Pad
- Shoulder Pipe Adjustment
- Backrest Adjustment
- Movable Pad
- Suitable for general J-bar type carrier for Tenor drums that have 14mm diameter rod
- Not fit to Tama Marching Tenor Drums

**2.035,00**

## SILVER ARMOR CARRIER "HOOK TYPE" FOR BASS DRUM



### CSABDM

- Sliding Height Adjustment
- Two-way Support Bar
- Belly Pad
- Shoulder Pipe Adjustment
- Backrest Adjustment
- Movable Pad
- Suitable for general locking type of carrier for bass drum with eyebolt. The distance between eyebolt hook can be adjustable within the range from 165mm to 250mm.
- Not fit to Tama Marching Bass Drums

**2.035,00**

## STARLIGHT CARRIER FOR SNARE DRUM



### CRSDT

- Sliding Height Adjustment
- Safety Lock Mount

**1.341,00**

## STARLIGHT CARRIER FOR TENOR DRUM



### CRTNT

- Sliding Height Adjustment
- Safety Lock Mount

**1.341,00**

## STARLIGHT CARRIER FOR BASS DRUM



### CRBDT

- Sliding Height Adjustment
- Safety Lock Mount
- Two-way Support Bar

**1.341,00**

## SAFETY LOCK MARCHING STAND FOR SNARE DRUM



### HMSD79WSN

- Snare Anti-Shake Bumper
- Upside Down Setting
- Safety Lock Mount
- Center of Gravity Position
- Adjustable 2 Front Legs
- Glide-Tite Grip Joint
- Double Braced Legs

**1.254,00**

## SAFETY LOCK MARCHING STAND FOR TENOR DRUM



### HMTN79WSZ

- Fold and Positioning Bar
- Tenor Anti-Chace Support Bar
- Safety Lock Mount
- Center of Gravity Position
- Adjustable 2 Front Legs
- Glide-Tite Grip Joint
- Double Braced Legs

**1.384,00**

## UNIVERSAL MARCHING STAND FOR BASS DRUM



### HMBD79WSM

- Center of Gravity Position
- Adjustable 2 Front Legs
- Glide-Tite Grip Joint
- Double Braced Legs

**1.211,00**

## SAFETY LOCK MARCHING NON STADIUM STAND FOR SNARE DRUM



### HMSD79WN

- Snare Anti-Shake Bumper
- Upside Down Setting
- Safety Lock Mount
- Center of Gravity Position
- Glide-Tite Grip Joint
- Double Braced Legs

**1.037,00**

## SAFETY LOCK MARCHING NON STADIUM STAND FOR TENOR DRUM



### HMTN79WZ

- Fold and Positioning Bar
- Tenor Anti-Shake Support Bar
- Safety Lock Mount
- Center of Gravity Position
- Glide-Tite Grip Joint
- Double Braced Legs

**1.254,00**

## UNIVERSAL NON STADIUM MARCHING STAND FOR BASS DRUM



### HMBD79WM

- Center of Gravity Position
- Glide-Tite Grip Joint
- Double Braced Legs

**1.124,00**

## MARCHING DRUM PROTECT COVERS FOR SNARE DRUM



### CVS1412N

CVS1412N (for 14"x12" Snare Drum)

**125,00**

## MARCHING DRUM PROTECT COVERS FOR TENOR DRUM



### CVTL

**200,00**

## MARCHING DRUM PROTECT COVERS FOR BASS DRUM



### CVB2224N

CVB1416N (for 14"x16" Bass Drum)  
CVB1820N (for 18"x20" Bass Drum)  
CVB2224N (for 22"x24" Bass Drum)  
CVB2628N (for 26"x28" Bass Drum)  
CVB30N (for 30" Bass Drum)

**2.035,00**

## HOOP GRIP & Z-ROD FOR HI-HAT CYMBALS



### MC8ZH

Hoop Grip (MC8) & Z-Rod for Hi-Hat Cymbals (ZH) bundle package

**321,00**

## Z-ROD FOR HI-HAT CYMBALS



### ZHH

Z-rod for mounting Hi-Hat cymbals

Details:  
- Screw Type Hi-Hat Clutch

**195,00**



## SNARE PROJECTER



### TPS14W

For 14" Snare Drums

TPS14W (White)  
TPS14B2 (Black)  
TPS14C (Clear)

**191,00**

## BASS DRUM HOOP GUARD



### MBRG14

TAMA Hoop Guards can be securely locked to bass drum hoops using the friction of rubber cushions. The rubber cushions protect the hoops from scratches and the Hoop Guards protect the hoops from rim shots.

**100,00**

## BASS DRUM HOOP GUARD

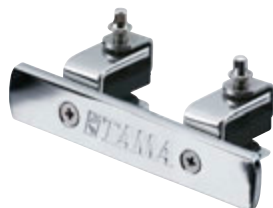

### MBHG100

TAMA Hoop Guards can be securely locked to bass drum hoops. The rubber cushions protect the hoops from scratches and the Hoop Guards protect the hoops from rim shots.

**109,00**

## Bass Drum Mallet Holder



### MBMH100

This mallet holder holds the 2 pairs of mallets by secure and easy retaining system. Also attaching this unit to bass drum without any screws tightening

**430,00**

## TAMA LOGO STICKER -White-



### TLS100WH

TLS120WH 60mm x 280mm	<b>20,00</b>
TLS100WH 50mm x 230mm	<b>19,00</b>
TLS80WH 40mm x 190mm	<b>19,00</b>
TLS70WH 35mm x 150mm	<b>19,00</b>

## TAMA LOGO STICKER -Black-



### TLS100BK

TLS120BK 60mm x 280mm	<b>20,00</b>
TLS100BK 50mm x 230mm	<b>19,00</b>
TLS80BK 40mm x 190mm	<b>19,00</b>
TLS70BK 35mm x 150mm	<b>19,00</b>

## GUT FRAME ASSEMBLY



### MGF14BR

TAMA Brown Guts are produce a crisp and warm sound. The gut frame can be instantly changed to produce the sound of your choice.

**543,00**

## SNARE MUTE



### MSMT

**100,00**

## MULTI LOCK CLAMP



### MLC79

**226,00**

## BASS DRUM MUFFLE RINGS



### MBSP2

(2pcs/set)

**78,00**

## TURNING KEY



### THDK20

Hi-Tension Tuning Key

**78,00**

## BACK SUPPORT BELT FOR CARRIER



### CSABSB

The Back Support Belt gives extra support while reducing back stress. Designed to be used with TAMA Silver Armor Carriers, (sold separately), it can be easily adjusted for different body types and is removable.

**161,00**

# CONCERT PERCUSSION

We offer Concert Percussion lineup with snare drums, toms, and hardwares.

STARPHONIC Concert Snare Drums are built to the absolute pinnacle of quality and design, and they carry a sound that's to be expected from any instrument bearing the name TAMA.

## BILL PLATT SIGNATURE



### BP146

MADE IN JAPAN

Shell: 3mm Bell Brass w/3 Air Vents  
Size: 14"x6"  
Lug: Freedom Lug  
Hoop: Grooved Straight Hoop (10 tension)  
Strainer: MLS50AD/MLS50BD w/ Multi Snare Frame  
Snare Wire: Three Different Snare Wire  
Nickel Wound Round Guitar String (MS6NW14M, 6 strands)  
Black Nylon Coated Stainless Steel Wire

**10.325,00**

## STARPHONIC MAPLE BRAVURA CONCERT



Color: Gloss Mocha Brown -GMC

### CMP146MF

MADE IN JAPAN

Shell: 6mm, 7ply 100% Maple  
Size: 14"x6"  
Lug: Freedom Lug  
Hoop: Grooved Straight Hoop (10 hole)  
Strainer/Butt: MLS50AD/MLS50BD w/Multi Snare Frame  
Snare Wire: Three Different Snare Wire  
Nickel Wound Round Guitar String (6 strands)

**3.771,00**

## STARPHONIC MAPLE CONCERT



Color: Piano Black -PBK

### CMP146

MADE IN JAPAN

Shell: 6mm, 7ply 100% Maple  
Size: 14"x6"  
Lug: Freedom Lug  
Hoop: Grooved Straight Hoop (10 hole)  
Strainer/Butt: MLS50AC/MLS50BC w/Fine Adjuster  
Snare Wire: Hybrid Snare Wire  
Nickel Wound Round Guitar String (6 strands in the center)

**2.817,00**

## STARPHONIC BUBINGA BRAVURA CONCERT



Color: Gloss Natural Cordia -GNC

### CBC146MF

MADE IN JAPAN

Shell: 7mm, 7ply 100% Bubinga + 1 outer ply Cordia  
Size: 14" x 6"  
Lug: Freedom Lug  
Hoop: Grooved Straight Hoop (10 hole)  
Strainer/Butt: MLS50AD/MLS50BD w/ Multi Snare Frame  
Snare Wire: Three Different Snare Wire  
Nickel Wound Round Guitar String (6 strands)

**4.205,00**

## STARPHONIC ALUMINUM BRAVURA CONCERT



### CAL146MF

MADE IN JAPAN

Shell: 3mm Aluminum  
Size: 14"x6"  
Lug: Freedom Lug  
Hoop: Grooved Straight Hoop  
Strainer/Butt: MLS50AD / MLS50BD w/Multi Snare Frame  
Snare Wire: Three Different Snare Wire  
Nickel Wound Round Guitar String (6 strands)

**4.205,00**

## STARPHONIC ALUMINUM CONCERT



### CAL146

MADE IN JAPAN

Shell: 3mm Aluminum  
Size: 14"x6"  
Lug: Freedom Lug  
Hoop: Grooved Straight Hoop  
Strainer/Butt: MLS50AC / MLS50BC w/Fine Adjuster  
Snare Wire: Hybrid Snare Wire

**3.251,00**

## STARPHONIC WALNUT BRAVURA FIELD DRUM



Color: Gloss Black Walnut (GBW)

### CWN1414MF

MADE IN JAPAN

Shell: 6mm, 6ply 100% Walnut  
 Size: 14"x14"  
 Lug: Freedom Lug  
 Hoop: Grooved Straight Hoop (10 hole)  
 Strainer/Butt: MLS50AD/MLS50BD w/Multi Snare Frame  
 Snare Wire: Three Different Snare Wire  
 Nickel Wound Round Guitar String (6 strands)

**5.160,00**

## CONCERT MAPLE



Color: Piano Black (PBK)

### CLMP1465

Shell: 6mm, 7ply 100% Maple  
 Size: 14"x6.5"  
 Lug: MTL60  
 Hoop: Steel Mighty Hoop (10 hole)  
 Strainer/Butt: MLS50AC/MLS50BC w/Fine Adjuster  
 Snare Wire: Hybrid Snare Wire  
 Nickel Wound Round Guitar String (6 strands in the center)

**1.949,00**

## CONCERT MAPLE



Color: Vintage Antique Maple (VAM)

### CLMP145

Shell: 6mm, 7ply 100% Maple  
 Size: 14"x5"  
 Lug: MTL50  
 Hoop: Steel Mighty Hoop (10 hole)  
 Strainer/Butt: MLS50AC/MLS50BC w/Fine Adjuster  
 Snare Wire: Hybrid Snare Wire  
 Nickel Wound Round Guitar String (6 strands in the center)

**1.862,00**

## CONCERT TOM SET -SINGLE HEAD-



Color: Vintage Antique Maple -VAM-

### CSLT4H

High-Pitched Concert Tom Set  
 6"x6" Tom Tom, 8"x7" Tom Tom, 10"x8" Tom Tom, 12"x9" Tom Tom  
 - 100% Maple Shell  
 - Direct-Flexi Mount  
 [Available Finishes]  
 -Vintage Antique Maple (VAM)  
 -Transparent Black Fade (TBF)

**2.730,00**

## CONCERT TOM SET -SINGLE HEAD-



Color: Vintage Antique Maple -VAM-

### CSLT4M

Mid-Pitched Concert Tom Set  
 10"x8" Tom Tom, 12"x9" Tom Tom, 13"x11" Tom Tom, 14"x12" Tom Tom  
 - 100% Maple Shell  
 - Direct-Flexi Mount  
 [Available Finishes]  
 -Vintage Antique Maple (VAM)  
 -Transparent Black Fade (TBF)

**3.251,00**

## CONCERT TOM SET -SINGLE HEAD-



Color: Vintage Antique Maple -VAM-

### CSLT4L

Low-Pitched Concert Tom Set  
 12"x10" Tom Tom, 13"x11" Tom Tom, 14"x12" Tom Tom, 16"x13" Tom Tom  
 - 100% Maple Shell  
 - Direct-Flexi Mount  
 [Available Finishes]  
 -Vintage Antique Maple (VAM)  
 -Transparent Black Fade (TBF)

**3.685,00**

## CONCERT TOM -SINGLE HEAD-



Color: Vintage Antique Maple -VAM-

### CSLT6A

6"x6" Tom Tom

[Available Finishes]  
 --Vintage Antique Maple (VAM)  
 -Transparent Black Fade (TBF)

**647,00**

## CONCERT TOM -SINGLE HEAD-



Color: Vintage Antique Maple -VAM-

### CSLT8A

8"x7" Tom Tom

[Available Finishes]  
 --Vintage Antique Maple (VAM)  
 -Transparent Black Fade (TBF)

**690,00**

## CONCERT TOM -SINGLE HEAD-



Color: Vintage Antique Maple -VAM-

### CSLT10A

10"x8" Tom Tom

[Available Finishes]  
 --Vintage Antique Maple (VAM)  
 -Transparent Black Fade (TBF)

**777,00**

## CONCERT TOM -SINGLE HEAD-



Color: Vintage Antique Maple -VAM-

### CSLT12A

12"x9" Tom Tom

[Available Finishes]  
 --Vintage Antique Maple (VAM)  
 -Transparent Black Fade (TBF)

**864,00**

## CONCERT TOM -SINGLE HEAD-



Color: Vintage Antique Maple -VAM-

### CSLT12D

12"x10" Tom Tom

[Available Finishes]  
 -Vintage Antique Maple (VAM)  
 -Transparent Black Fade (TBF)

**864,00**

## CONCERT TOM -SINGLE HEAD-



Color: Vintage Antique Maple -VAM-

### CSLT13D

13"x11" Tom Tom

[Available Finishes]  
 -Vintage Antique Maple (VAM)  
 -Transparent Black Fade (TBF)

**950,00**

## CONCERT TOM -SINGLE HEAD-



### CSLT14D

14"x12" Tom Tom

[Available Finishes]  
-Vintage Antique Maple (VAM)  
-Transparent Black Fade (TBF)

**1.037,00**

Color: Vintage Antique Maple -VAM-

## CONCERT TOM -SINGLE HEAD-



### CSLT16D

16"x14" Tom Tom

[Available Finishes]  
-Vintage Antique Maple (VAM)  
-Transparent Black Fade (TBF)

**1.298,00**

Color: Vintage Antique Maple -VAM-

## CONCERT TOM SET -DOUBLE HEAD-



### CCLT4H

High-Pitched Concert Tom Set  
6"x6" Tom Tom, 8"x7" Tom Tom, 10"x8" Tom Tom, 12"x9" Tom Tom

- 100% Maple Shell  
- Direct-Flexi Mount  
[Available Finishes]  
-Vintage Antique Maple (VAM)  
-Transparent Black Burst (TPB)

**2.947,00**

Color: Transparent Black Burst -TPB-

## CONCERT TOM SET -DOUBLE HEAD-



### CCLT4M

Mid-Pitched Concert Tom Set  
10"x8" Tom Tom, 12"x9" Tom Tom, 13"x11" Tom Tom, 14"x12" Tom Tom

- 100% Maple Shell  
- Direct-Flexi Mount  
[Available Finishes]  
-Vintage Antique Maple (VAM)  
-Transparent Black Burst (TPB)

**3.468,00**

Color: Transparent Black Burst -TPB-

## CONCERT TOM SET -DOUBLE HEAD-



### CCLT4L

Low-Pitched Concert Tom Set  
12"x10" Tom Tom, 13"x11" Tom Tom, 14"x12" Tom Tom, 16"x14" Tom Tom

- 100% Maple Shell  
- Direct-Flexi Mount  
[Available Finishes]  
-Vintage Antique Maple (VAM)  
-Transparent Black Burst (TPB)

**3.902,00**

Color: Transparent Black Burst -TPB-

## CONCERT TOM -DOUBLE HEAD-



### CCLT6A

6"x6" Tom Tom

[Available Finishes]  
-Vintage Antique Maple (VAM)  
-Transparent Black Burst (TPB)

**690,00**

Color: Transparent Black Burst -TPB-

## CONCERT TOM -DOUBLE HEAD-



### CCLT8A

8"x7" Tom Tom

[Available Finishes]  
-Vintage Antique Maple (VAM)  
-Transparent Black Burst (TPB)

**733,00**

Color: Transparent Black Burst -TPB-

## CONCERT TOM -DOUBLE HEAD-



### CCLT10A

10"x8" Tom Tom

[Available Finishes]  
-Vintage Antique Maple (VAM)  
-Transparent Black Burst (TPB)

**820,00**

Color: Transparent Black Burst -TPB-

## CONCERT TOM -DOUBLE HEAD-



### CCLT12A

12"x9" Tom Tom

[Available Finishes]  
-Vintage Antique Maple (VAM)  
-Transparent Black Burst (TPB)

**907,00**

Color: Transparent Black Burst -TPB-

## CONCERT TOM -DOUBLE HEAD-



### CCLT12D

12"x10" Tom Tom

[Available Finishes]  
-Vintage Antique Maple (VAM)  
-Transparent Black Burst (TPB)

**907,00**

Color: Transparent Black Burst -TPB-

## CONCERT TOM -DOUBLE HEAD-



### CCLT13D

13"x11" Tom Tom

[Available Finishes]  
-Vintage Antique Maple (VAM)  
-Transparent Black Burst (TPB)

**994,00**

Color: Transparent Black Burst -TPB-

## CONCERT TOM -DOUBLE HEAD-



### CCLT14D

14"x12" Tom Tom

[Available Finishes]  
-Vintage Antique Maple (VAM)  
-Transparent Black Burst (TPB)

**1.167,00**

Color: Transparent Black Burst -TPB-

## CONCERT TOM -DOUBLE HEAD-



Color: Transparent Black Burst -TPB-

### CCLT16D

16"x14" Tom Tom

[Available Finishes]  
-Vintage Antique Maple (VAM)  
-Transparent Black Burst (TPB)

**1.341,00**

## CONCERT SNARE STAND - ROADPRO



### HS80HWN

For 12" to 15" Diameter Snare Drums

-Quick-Set Tilter  
-Swiveling Basket  
-Glide-Tite Grip Joint  
-Double Braced Legs  
-Weight: 3.7kg (8.2lbs)  
-Height Adjustment Range: 640mm - 925mm  
(25 3/16" - 36 3/8")

**560,00**

## CONCERT SNARE STAND - THE CLASSIC STAND



### HS50HF

-Flat Base Leg Design  
-Classic Style Basket  
-Double Braced Arms  
-Gearless Tilter  
-Weight: 1.9kg (4.2lbs)  
-Height Adjustment Range: 630mm-860mm (24 13/16" - 33 7/8")

**386,00**

## DOUBLE TOM STAND



### HTW839W

-28.6mm Diameter Base Section Tubing  
-Omni-Ball Tom Angle Adjustment  
-Stilt System  
-Glide-Tite Grip Joint  
-Double Braced Legs  
-Weight: 5.0kg (11 lbs)  
-Height Adjustment Range: 790-1,270mm (31 1/8" - 50")

**1.081,00**

## PERCUSSION TABLE



### HTB86LS

-25.4mm Diameter Base Section Tubing  
-Table Size: 600mm width x 450mm length  
-Glide-Tite Grip Joint  
-Single Braced Legs  
-Weight: 5.5kg (12.1lbs)

**907,00**

## POWERPAD BAG -Concert Snare Drum-



### PBSC146

-For Tama Concert Snare Drum  
-Five-Layered Semi-Hard Resin Structure  
-30mm Groove to Securely House Multi Snare Frame

**486,00**

"Model" stands for the item number as used by Roland Meinl Musikinstrumente GmbH & Co KG ("Meinl").

Each price as specified is the manufacturer's suggested retail price (MSRP), applicable as of 01.07.2024 and subject to change.

Dealers and other resellers remain free to set their own retail prices at all times.

Price and model changes as well as changes to technical data are reserved without prior announcement.

No liability is assumed for setting, printing and colour errors.

Roland Meinl Musikinstrumente GmbH & Co. KG | Musik-Meinl Str. 1 | 91468 Gutenstetten | Germany

Phone: +49 9161 7880 | E-Mail: [tama.pl@meinldistribution.eu](mailto:tama.pl@meinldistribution.eu) | [tamadrum.pl](http://tamadrum.pl)

Roland Meinl Musikinstrumente GmbH & Co KG Spółka komandytowa Oddział w Polsce. | ul.Przemysłowa 20 | 21-100 Lubartów | Polska